

Multi-Directional PIR Sensor

HIR27/AA

DALI Output & Daylight harvest

HYTRONIK®



Product Description

HIR27/AA is a PIR standalone motion sensor, with one DALI channel output (80mA DALI power supply built-in). It is designed with a metal surface mount box and the detection angle is adjustable by needs. HIR27/AA is ideal for typical indoor applications such as offices, classrooms, healthcare, and other commercial areas (corridors and warehouses).



Features

- Daylight harvest function to regulate light output for maintaining required lux level.
- Store settings in the remote for easy commissioning when programming multiple sensors.
- Intelligent photocell - lights and sensors only operate when needed, natural light has priority.
- DALI bus power supply
 - I guaranteed: 64mA
 - I max: 80mA
 - U rated: 15VDC
- Support to control DT6 LED drivers
- 1 Push inputs for flexible manual control
- Black & White & Gray metal surface mount box options
- User-friendly design for installation
- 5-year warranty

Technical Specifications

Input & Output Characteristics	
Operating voltage	220-240VAC 50/60Hz
Stand-by power	<0.5W

Sensor Data	
Sensor Principle	PIR Detection
Ceiling-mounted Detection Range	Installation Height: 3m Max. Detection Range: 15m *Sensor head angle set to 70°
Wall-mounted Detection Range	Installation Height: 2.5m Max. Detection Range: 13m
Detection angle	360°

*For more details of detection range, please refer to "detection pattern" section.

DALI Bus Power Supply	
I guaranteed	60mA
I max	90mA
U rated	15VDC

Environment	
Operation temperature	Ta: -20°C ~ +50°C
Storage temperature	-25°C ~ +70°C
Relative humidity	10-90%
IP rating	IP20

Safety & EMC	
EMC standard (EMC)	EN55015, EN61000-3-2/-3-3, EN61547
Safety standard (LVD)	EN60669-1, EN60669-2-1
RED	EN300328, EN301489-1/-17, EN50663
Certification	CE, UKCA, RED, RCM

Mechanical Structure & Dimensions

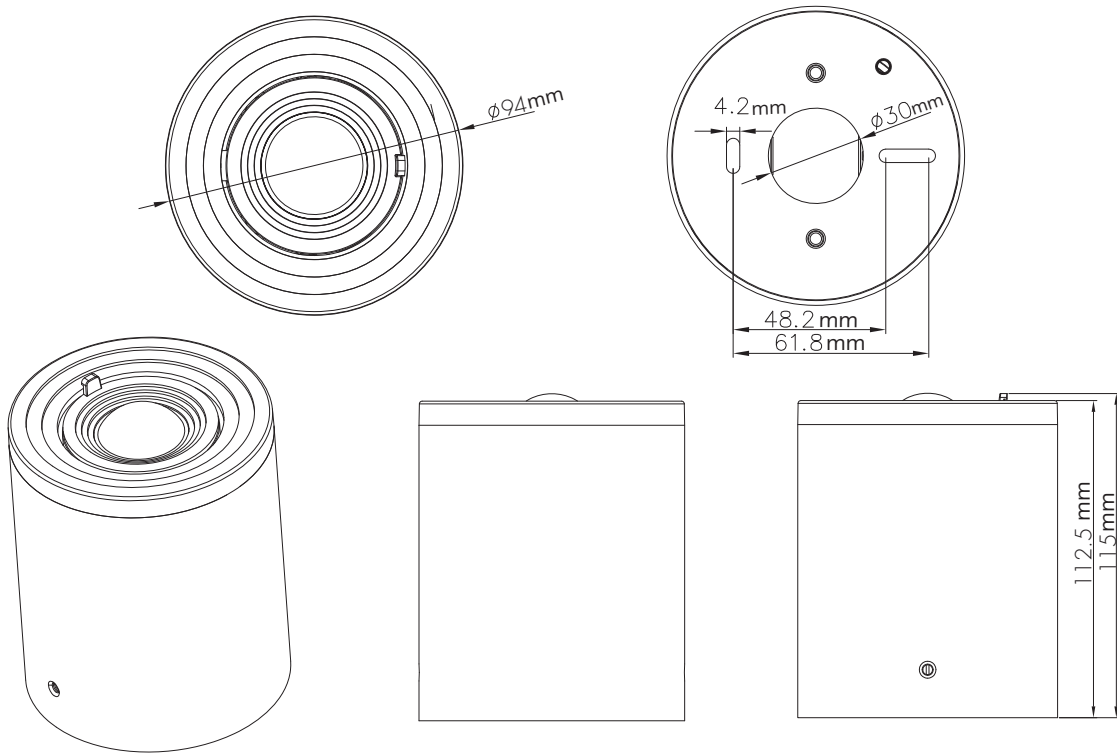

Wiring Diagram

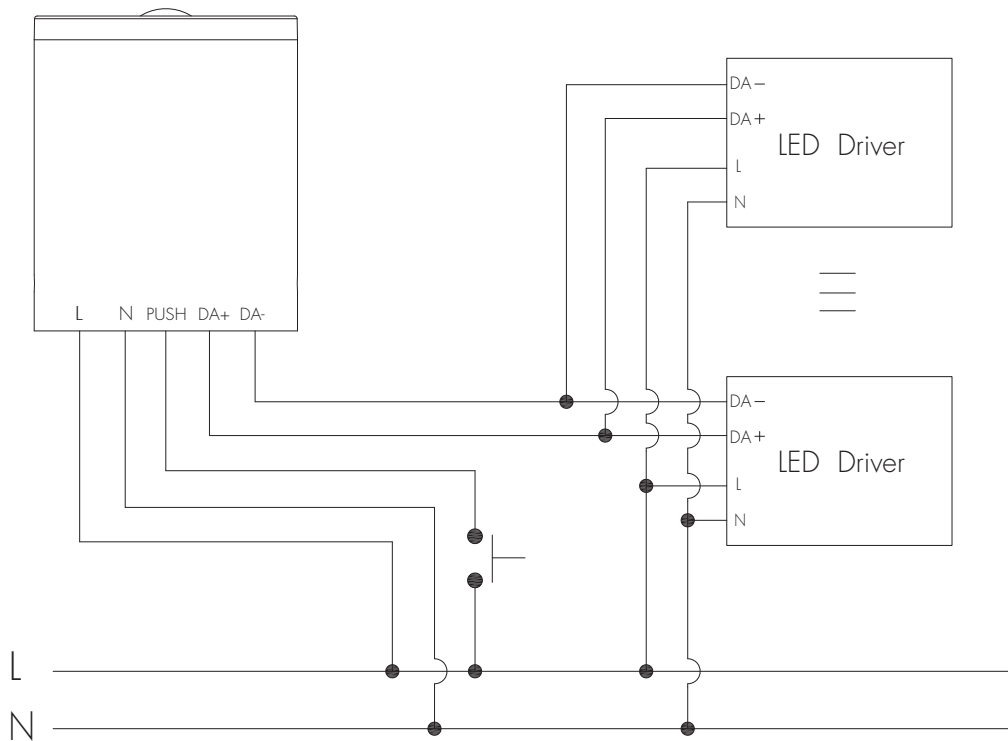

1. 200 metres (total) max. for 1mm^2 CSA ($T_a = 50\text{ C}$)
 2. 300 metres (total) max. for 1.5mm^2 CSA ($T_a = 50\text{ C}$)

Detection Pattern

*Sensitivity set to maximum

Ceiling-mounted application

Installation height: 3m

*Sensor head angle set to 70°

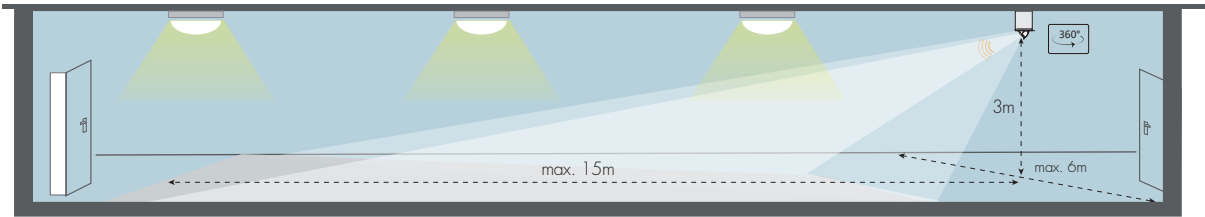

Installation height: 3m

*Sensor head angle set to 90°

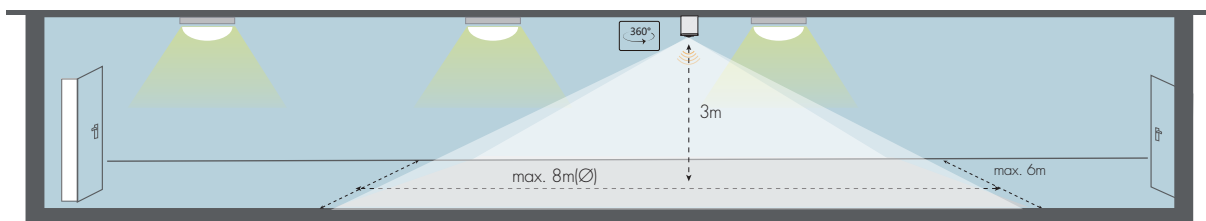

Wall-mounted application

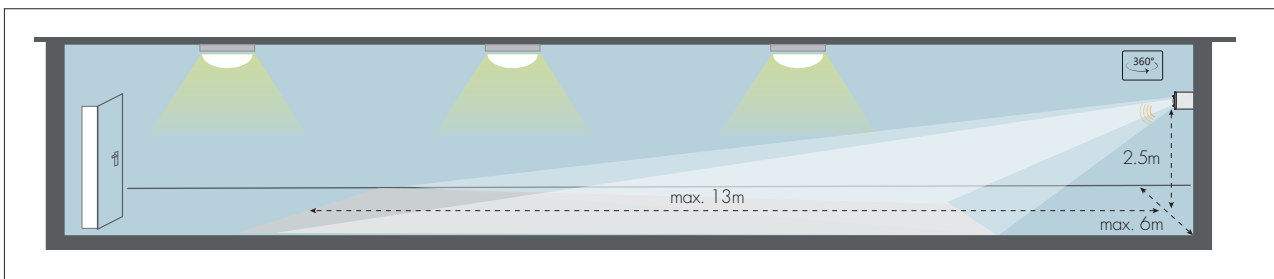

The installation data conduct by following testing conditions:

1. Environmental humidity: 80.5%;
2. Single person walking;
3. Sensor not connected to any driver that may have soft-on period;
4. Testing temperature $T_a = 31.5^\circ\text{C}$;
5. Sensitivity set to maximum;
6. The testing is conducted in an open and spacious indoor field, without noticeable obstacles or influences that may affect PIR performances.

Application	Angle	Height	Tangential /Radial	Detection range
Ceiling-mounted	90°	5m	Tangential	10m(Ø)
			Radial	4m(Ø)
	70°		Tangential	11m
			Radial	6m
	90°	3m	Tangential	8m(Ø)
			Radial	4m(Ø)
70°		Tangential	15m	
		Radial	3m	
Wall-mounted	90°	2.5m	Tangential	13m
			Radial	2m

Note: The unit for 90 degree detection data in the case of ceiling installation is diameter.

Ceiling-mounted application

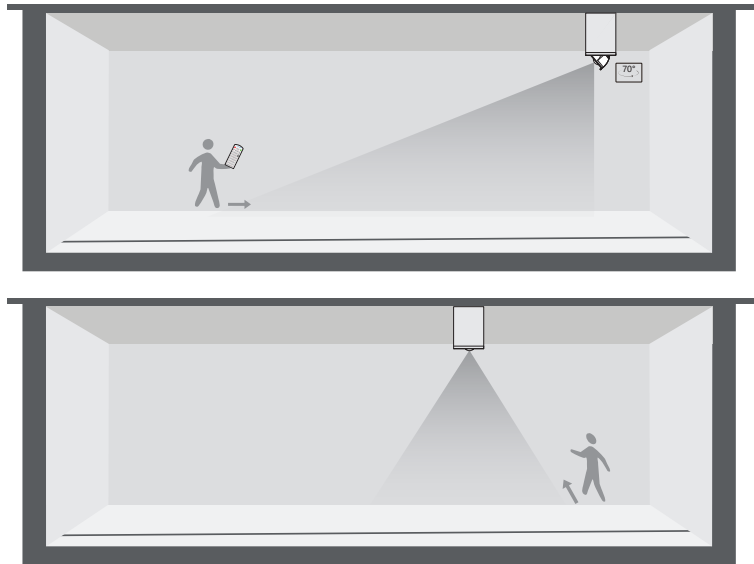

Wall-mounted application



Functions and Features

1 Daylight Harvest



Right time, right place and the right amount of light! Daylight harvest (Also known as daylight regulating or daylight interaction) is a must in the future lighting norms. The daylight sensor measures the available surrounding natural light and calculates how much artificial light is needed to reach the target lux level. The control output is passed to the drivers by DALI or 0/1-10V signals which then deliver the needed amount of light.



The light will not switch on when natural light is sufficient, even with motion detected.



The light switches on automatically with presence when natural light is insufficient.



The light turns on at full or dims to maintain the lux level. The light output regulates according to the level of natural light available.



The light will be switched off when the ambient natural light is sufficient.



The light dims to stand-by brightness after hold-time and stays on the selected minimum dimming level.



The light switches off automatically after the stand-by period.

In the old days, to configure a daylight harvest application is not simple in real life, as it usually involves professional installers or lighting specialists with good lighting industry background and needs special equipment on site, which is not quite accessible by public users.

Aiming to simplify the daylight harvesting setup and make life easier for users, Hytronik has developed intuitive features that revolutionizes the commissioning processes --- Users can now easily commission daylight harvesting quickly and effortlessly!

2 Manual Override

With the help of push-switch, this sensor can be over-riden by the end-user to manually switch on/off the light, or adjust the target lux level by push-switch, which makes the product more user-friendly and offers more options to fit some extra-ordinary demands:

* Short Push (<1s): on/off function;

On → Off: the light turns off immediately and cannot be triggered ON by motion until the expiration of pre-set hold-time. After this

period, the sensor goes back to normal sensor mode.

Off → On: the light turns on and goes to sensor mode, no matter if ambient Lux level exceeds the daylight threshold or not.

* Long Push (>1s): adjust the target lux level by turning the light up or down. Both the adjustment on remote control and push switch can overwrite each other. The last adjustment remains in memory.

Note: if end-user do not want this manual override function, just leave the “push” terminal unconnected to any wire.

3 Semi-auto Mode (Absence Detection)

Selecting this mode will activate the following logic:

Manual on - The lights will not switch on until they have manually been switched on at the wall switch. The occupancy sensor is inactive whilst the lights are off.

Auto off - When the lights are on, the sensor becomes active and monitors the space for activity. Once the area is vacated (absence detection), the sensor will automatically switch off the lights if the last person out forgets to switch off the light manually.

Settings (Remote Control HRC-11)

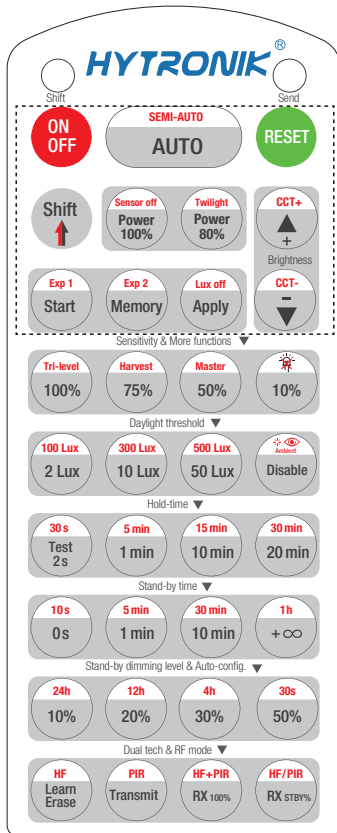

HRC-11

	Press button "ON/OFF" to select permanent ON or permanent OFF mode. * Press button "AUTO" / "RESET" to exit this mode.
	Press button "RESET", all settings go back to default. The default settings are: Auto mode; Detection range 100%; Hold-time 5min; Daylight sensor 100Lux; Stand-by time 10min; Stand-by dimming level 20%; Lux off activated.
	Press button "Shift", the LED on the top left corner is on to indicate mode selection. All values / settings in RED are valid for 20 seconds.
AUTO	Press button "AUTO" to initiate automatic mode. The sensor starts working and all settings remain as before the light is switched ON/OFF;
SEMI-AUTO	1. Press button "Shift", the red LED on. 2. Press button "SEMI-AUTO" to initiate Semi-auto mode. The sensor is only activated with the manual press of push switch. To exit this mode, simply press button "AUTO". For Sensor LED indicator references: Remains on 2s, initiate "Semi-auto" mode from "Auto" mode.
Power 100% 80%	Press buttons in zone "Power out" to select the light output at 80% (at initial 10,000 hours) or 100%.
Sensor off	This key is not applicable on this product.
Twilight	1. Press button "Shift", the red LED on. 2. Press button "Twilight", the function of movement detection is disabled, but the function of photocell is still working, and the product becomes a pure dusk/ dawn daylight sensor. To exit from "Twilight" mode, press button "AUTO"/"SEMI-AUTO"/"RESET".
	Press these two buttons to adjust the light output brightness and set a new target lux level. The daylight sensor can measure ambient daylight level and ignore the LED light, so as to calculate how much artificial light is needed to maintain the target lux level.
CCT+ CCT-	This key is not applicable on this product.
Start Memory Apply	1. Press button "Start" to program. 2. Select the buttons in "Detection range", "Daylight threshold", "Hold-time", "Stand-by time", "Stand-by dimming level" to set all parameters. 3. Press button "Memory" to save all the settings programmed in the remote control. 4. Press button "Apply" to set the settings to each sensor unit(s). For example, to set detection range 100%, daylight threshold Disable, hold-time 5min, stand-by time + ∞, stand-by dimming level 30%, the steps should be: Press button "Start", button "100%", "Disable", "Shift", "5min", "Shift", "+∞", "30%", "Memory". By pointing to the sensor unit(s) and pressing "Apply", all settings are passed on the sensor(s).
Lux off	The "Lux off" function is activated as default. When the ambient lux level exceeds the target level continuously for more than 5 minutes, the lights will be turned off. In AUTO /SEMI-AUTO/Twilight modes, to disable "Lux off": 1. Press "Shift" button first, the red LED on. 2. Press "Lux off" button, the "Lux Off" function will be deactivated. The lights will not turn off even when the ambient lux level exceeds the target lux level but will dim down the brightness to the stand-by time level. For Sensor LED indicator references: 1. Fast flash 1s, "Lux off" function activated. 2. Remains on 2s, "Lux off" function deactivated.
Exp 1 Exp 2	This key is not applicable on this product.

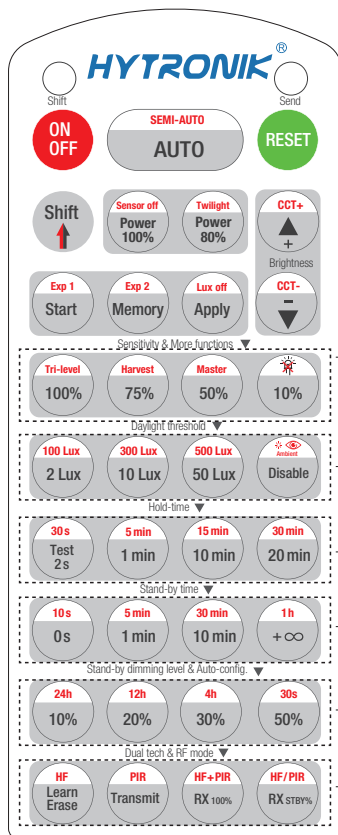

HRC-11

Sensitivity & More functions	
100% 75% 50% 10%	In AUTO /SEMI-AUTO modes, press buttons in zone "Detection range" to set detection range at 100%/75%/50%/10%.
Tri-level Harvest	This key is not applicable on this product.
Master	This key is not applicable on this product.
Daylight threshold	
2 Lux 100 Lux 10 Lux 300 Lux 50 Lux 500 Lux Disable	Press buttons in zone "Daylight threshold" to set daylight sensor at 2Lux / 10Lux / 50Lux / 100Lux / 300Lux/500Lux / Disable. Note: To set daylight sensor at 100Lux / 300Lux/500Lux , press "Shift" button first.
	1. Press button "Shift", the red LED on. 2. Press button "Ambient", the surrounding lux level is sampled and set as daylight threshold / target Lux level.
Hold-time mode	
Test 2s 30s 1min 5min 10min 15min 20min 30min	In AUTO /SEMI-AUTO modes, press buttons in zone "hold-time" to set the hold-time at 2s / 30s / 1min / 5min / 10min / 15min / 20min / 30min. Note: 1. To set hold-time at 30s / 5min / 15min / 30min, press "Shift" button first. 2. 2s is for testing purpose only, stand-by period and daylight sensor settings are disabled in this mode. *To exit from Test mode, press button "RESET" or any button in "Hold-time".
Stand-by time mode	
0s 10s 1min 5min 10min 30min +∞ 1h	Press buttons in zone "stand-by time" to set the stand-by period at 0s / 10s / 1min / 5min / 10min / 30min / 1h / +∞. Note: 1. To set stand-by-time at 10s/ 5min / 30min / 1h, press "Shift" button first. 2. "0s" means on/off control; 3. "+∞" means bi-level control, the fixture is 100% on when there is motion detected, and remains at the stand-by dimming level when no presence after motion hold-time. Only when the stand-by time is set in "+∞" and the ambient lux level is below the target lux level, the lux will auto-on.
Stand-by dimming level & Auto-config.	
10% 20% 30% 50%	Press the button in zone "stand-by dimming level" to set the stand-by dimming level at 10% / 20% / 30% / 50%.
24h 12h 4h 30s	1.Press button "Shift", the red LED on. 2.Select a time period and the sensor will do light level measurement and determine/save the lowest light level (commission line) with 100% light on, so as to set the target lux level automatically. Note:1.Make sure the light level measurement covers the night time. 2.The fixture will go into sensor mode after the measurement, all sensor setting remain unchanged.
Dual tech & RF mode	
Learn Erase Transmit	This key is not applicable on this product.
RX 100% RX STBY%	This key is not applicable on this product.
HF PIR HF+PIR HF/PIR	This key is not applicable on this product.

Dimming Interface Operation Notes

Switch-Dim

The provided Switch-Dim interface allows for a simple dimming method using commercially available non-latching (momentary) wall switches.

Switch Function	Action	Descriptions
Push switch	Short press (<1 second) * Short press has to be longer than 0.1s, or it will be invalid.	- Turn on/off - Recall a scene - Turn on only - Quit manual mode - Turn off only - Do nothing
	Double push	- Turn on only - Quit manual mode - Turn off only - Do nothing - Recall a scene
	Long press (≥ 1 second)	- Dimming - Colour tuning - Do nothing

Additional Information / Documents

1. Regarding precautions for PIR Sensors installation and operation, please kindly refer to www.hytronik.com/download → knowledge → PIR Sensors - Precautions for Product Installation and Operation
2. Regarding Hytronik standard guarantee policy, please refer to www.hytronik.com/download → knowledge → Hytronik Standard Guarantee Policy