

## IP65 Built-in PIR Motion Sensor

### HIR15P (High-Bay)

0-10V Dimming with Remote Control

# HYTRONIK®





CE IP65 UKCA

## Product Description

HIR15P is a 0-10V PIR motion sensor. HIR15P is also designed with a robust IP65 structure and suitable for high-bay applications as the capacity can be up to 12m installation height, which is ideal for the indoor applications such as warehouses and other commercial/industrial areas.



## Hardware Features

-  0-10V dimmable
-  IP65 design
-  High-bay (up to 12m height)
-  Remote controllable
-  5-year warranty

## Technical Specifications

### Input & Output Characteristics

Input voltage	12 V (20mA MAX.)
Stand-by power	<0.5W
Output voltage	0-10V
Warming up	20s (Initial power-on)

### Environment

Operation temperature	Ta: -20°C ~ +50°C
Storage temperature	-40°C ~ +70°C
Relative humidity	10 ~ 90%
Lux range	0-50 Lux
IP rating	IP65

### Sensor Data

Sensor principle	PIR
Detection range*	Max installation height: 12m Max diameter: 20m
Detection angle	360°

\* The detection range is heavily influenced by sensor placement (angle) and different walking paces. It may be reduced under certain conditions.

### Safety & EMC

EMC standard (EMC)	EN55015, EN61547
Safety standard (LVD)	EN61347-1/2-11
Certification	CE, UKCA
Compliance	RoHS Reach

# Mechanical Structure & Dimensions

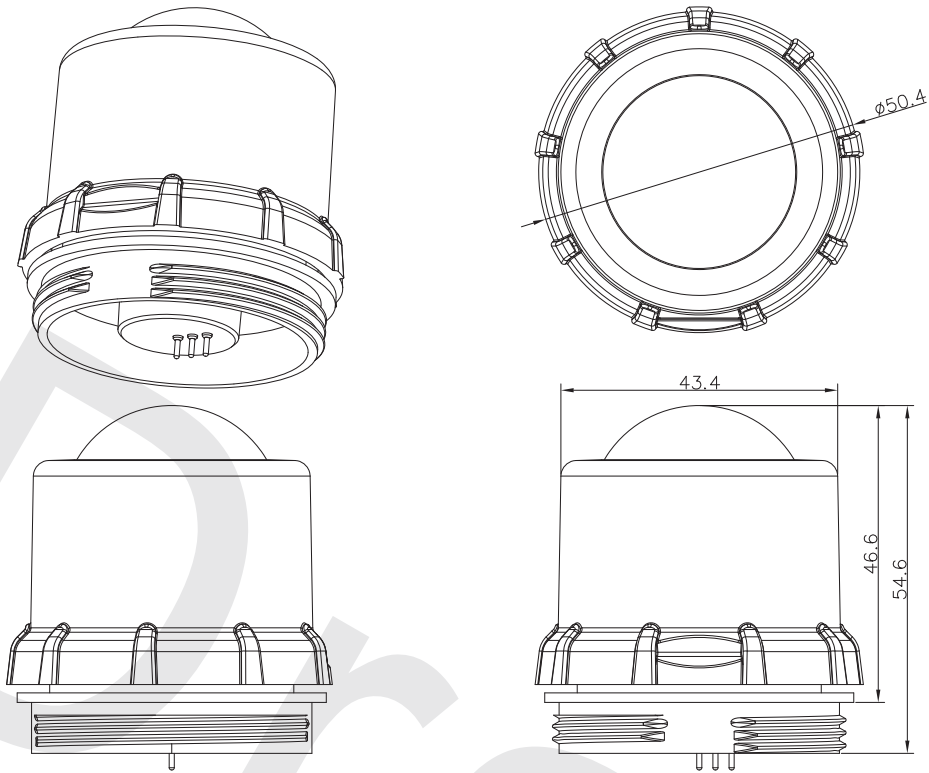

## Wiring Diagram

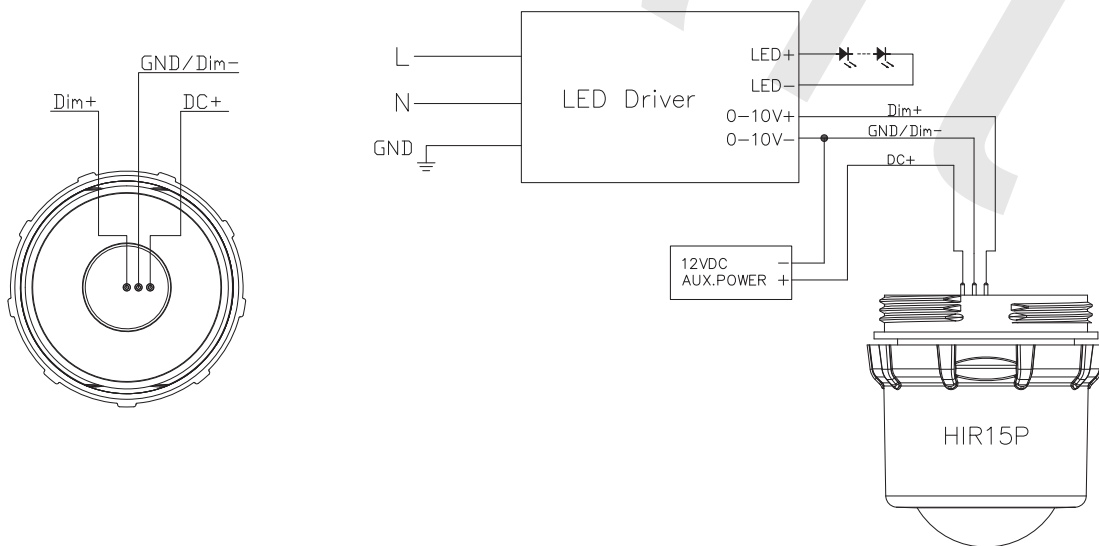

## Detection Range

The data below is tested under following conditions:

- Single person walking;
- Sensor not connected to any driver that may have soft-on period;
- Testing temperature  $T_a = 20^{\circ}\text{C}$ ;
- The testing is conducted in an open and spacious indoor field, without noticeable obstacles or influences that may affect PIR performances.

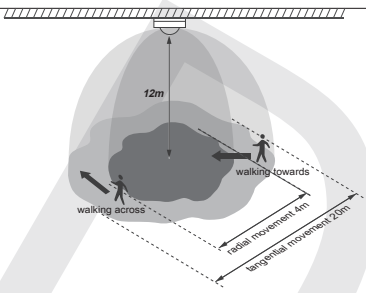

Mount height	Tangential Movement (A)	Radial Movement (B)
3m	max 50m <sup>2</sup> (∅ = 8m)	max 13m <sup>2</sup> (∅ = 4m)
5m	max 79m <sup>2</sup> (∅ = 10m)	max 13m <sup>2</sup> (∅ = 4m)
8m	max 154m <sup>2</sup> (∅ = 14m)	max 13m <sup>2</sup> (∅ = 4m)
12m	max 314m <sup>2</sup> (∅ = 20m)	max 13m <sup>2</sup> (∅ = 4m)

## Settings (Remote Control HRC-05)



### Permanent ON/OFF function

Press the "ON/OFF" button, the light goes to permanent on or permanent off mode, and the sensor is disabled.

\* Press "Auto Mode", "RESET" or "Scene mode" buttons to quit this mode.

The mode will change to AUTO Mode after power failure.



### Sensor mode

Press "Auto Mode" button, the sensor starts to function and all settings remain the same as the latest status before the light is switched on/off.



### Reset function

Press "RESET" button, all settings go back to default settings.

Detection range: 100%; Hold-time: 5 min; Stand-by period: 10min;

Stand-by dimming level: 20%; Lux disabled.



### Dim +/-

Long press "Dim +" or "Dim -" to adjust the light brightness during hold-time. "+" means dimming up, "-" means dimming down.



### Test mode

Press "Test 2s" button, the sensor goes to test mode (hold-time is 2s, daylight sensor and dimming control are disabled). Pressing "Reset" and "Hold-time", or any button of "Scene mode" to end this mode and change the pertinent sensor settings.

\* Press the buttons of "detection range" to set detection range.

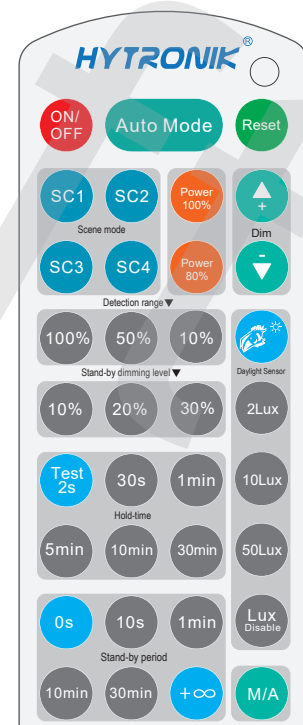

HRC-05

*Note: the buzzer beeps one time when RC receives signal successfully.*



### Power output

By pressing these two buttons, the output shifts between 80% (at initial 10,000 hours) and 100%, for energy saving purpose.



### Lux disable

Press this button, the built-in daylight sensor stops working, and all motion detected could turn on the lighting fixture, no matter how bright the natural light is.

### Scene mode

There are 4 scene modes fixed program built in the remote control to choose for different applications:

Scene options	Detection range	Hold-time	Stand-by period	Stand-by dimming level	Daylight sensor
SC1	100%	1 min	10min	10%	2Lux
SC2	100%	5min	10min	10%	2Lux
SC3	100%	10min	30min	10%	10Lux
SC4	100%	10min	+∞	10%	50Lux

\* End-user can adjust the settings by pressing buttons of detection range/hold-time/stand-by period/stand-by dimming level/daylight sensor. The last setting stays in validity.

### Detection range

Press the buttons of "detection range" to set detection range at 10% / 50% / 100%.

### Hold-time

Press the buttons of "hold-time" to set hold-time at 30s / 1min / 5min / 10min / 30min.

### Daylight sensor

Press the buttons of "daylight sensor" to set daylight threshold at 2Lux / 10Lux / 50Lux.

### Stand-by period (corridor function)

Press the buttons of "stand-by period" to set stand-by period at 0s / 10s / 1min / 10min / 30min / +∞.

\* "0s" means on/off control; "+∞" means bi-level dimming control, light never switches off when daylight sensor is disabled.

### Stand-by dimming level

Press the buttons of "stand-by dimming level" to set the stand-by dimming level at 10% / 20% / 30%.

## Additional Information / Documents

1. Regarding precautions for PIR sensor installation and operation, please kindly refer to [www.hytronik.com/download ->knowledge ->PIR Sensors - Precautions for Product Installation and Operation](http://www.hytronik.com/download->knowledge->PIR%20Sensors%20-%20Precautions%20for%20Product%20Installation%20and%20Operation)
2. Regarding Hytronik standard guarantee policy, please refer to [www.hytronik.com/download->knowledge ->Hytronik Standard Guarantee Policy](http://www.hytronik.com/download->knowledge->Hytronik%20Standard%20Guarantee%20Policy)