

## IP65 Dual Sense Sensor with Bluetooth® 5.0 SIG Mesh

### HIM98/UH (High Bay)

HF & PIR, Tri-level control & Daylight harvest, 0/1-10V Dimmable

# HYTRONIK®



UK  
CA IP65

### Product Description

HIM98/UH is a Bluetooth 0/1-10V high-bay Dual-sense (Microwave+ PIR) motion sensor, with a capability of up to 21 m installation height. It is designed with a robust IP65 structure and 3 different installation methods that can be chosen. Bluetooth wireless mesh networking makes communication much easier without any hardwiring, which eventually adds value to luminaires and saves project costs. Meanwhile, simple device setup and commissioning can be done via **Koolmesh®** app.



### App Features

- Quick setup mode & advanced setup mode
- Tri-level control
- Daylight harvest
- Circadian rhythm (Human centric lighting)
- Floorplan feature to simplify project planning
- Web app/platform for dedicated project management
- Koolmesh Pro iPad version for on-site configuration
- Grouping luminaires via mesh network
- Scenes
- Detailed motion sensor settings
- Dusk/Dawn photocell (Twilight function)
- Schedule to run scenes based on time and date
- Astro timer (sunrise and sunset)
- Staircase function (primary & secondary)
- Internet-of-Things (IoT) featured
- Device firmware update over-the-air (OTA)
- Device social relations check
- Bulk commissioning (copy and paste settings)
- Dynamic daylight harvest auto-adaptation
- Power-on status (memory against power loss)
- Offline commissioning
- Different permission levels via authority management
- Network sharing via QR code or keycode
- Remote control via gateway support HBGW01
- Interoperability with Hytronik Bluetooth product portfolio
- Compatible with EnOcean BLE switches
- Continuous development in progress...

### Hardware Features

- 0/1-10V dimming control method
- 4 Modes 4 work modes:
  - HF only
  - PIR only
  - HF + PIR
  - HF / PIR
- 3 Meth 3 installation methods
- IP IP65 design
- High-bay (up to 21m height)
- 5-year warranty

**Bluetooth® Kinetic Switch**

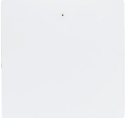

HBKS01



HBKS02



HBKS03



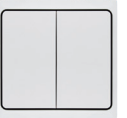

HBKS01D





HBKS02D

---













EnOcean  
Self-powered IoT

Fully support EnOcean self-powered switch module  
PTM215B (HBES01/W & HBES01/B)

**Bluetooth® 5.0 SIG mesh**







iOS



for iOS



Android



for Android

Smartphone app for both iOS & Android platform

---







for iPad

Koolmesh Pro app for iPad

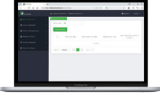
---





Web



for Web

Web app/platform: [www.iot.koolmesh.com](http://www.iot.koolmesh.com)

## Technical Data

### Input Characteristics

Model No.	
Mains voltage	220-240VAC 50/60Hz
Stand-by power	<1.5W
Load ratings:	
Capacitive	800VA
Resistive	1000W
Warming-up	20s

### Safety and EMC

EMC standard (EMC)	EN55015, EN61000-3-2/-3-3
Safety standard (LVD)	EN60669-1, EN60669-2-1
Radio Equipment (RED)	EN300440, EN301489-1/-17/-3, EN300328, EN50663
Certification	UKCA, CE, RED, RCM

### Sensor Data

Model No.	
Sensor principle	High Frequency (microwave), PIR
Operation frequency	5.8GHz +/- 75MHz (HF)
Transmission power	<0.2mW (HF)
Sensor mode	4 modes: PIR, HF, PIR+HF, PIR/HF
Detection range	Max installation height: HF: Ø = 15m (forklift)/12m (human) PIR: 21m Max detection range: HF: Ø = 24m (forklift)/20m (human) PIR: Ø = 26m
Detection angle	360°

### Environment

Operation temperature	Ta: -20°C ~ +50°C
IP rating	IP65

## Mechanical Structures and Installations

For more details, please refer to user manual.

### A. Ceiling mount (HIM98/UH-A)

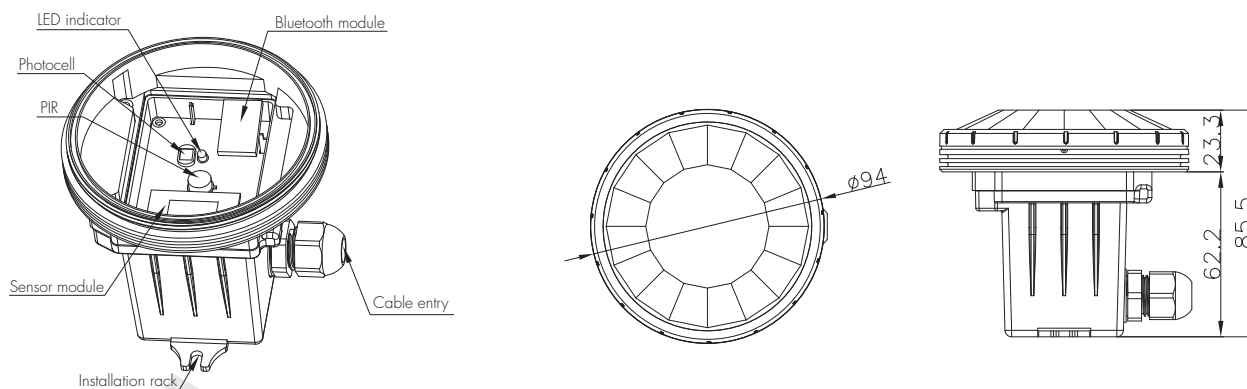

### B. Screw to the Luminaire by conduit (HIM98/UH-B)

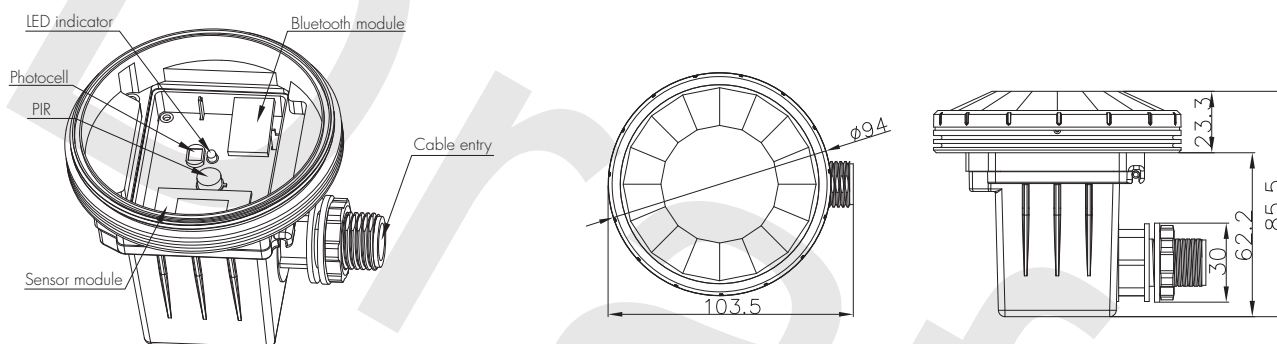

### C. Attach to the shade by clamp (HIM98/UH-C)

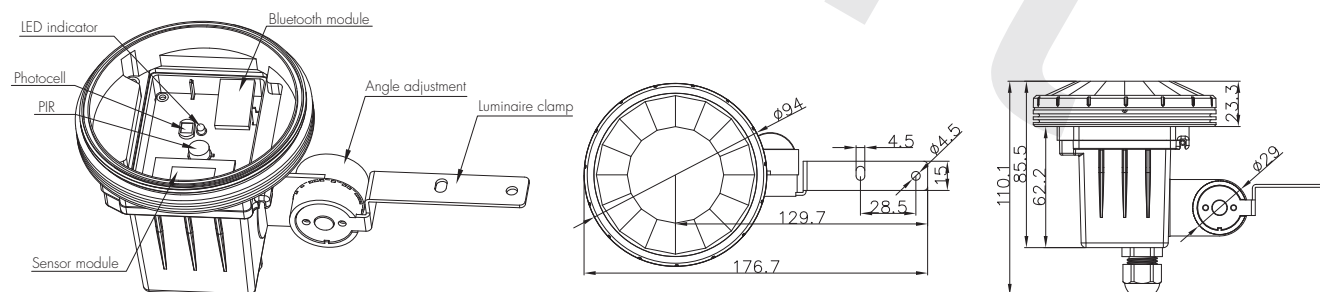

Note: We recommend the mounting distance between sensor to sensor should be more than 2m to prevent sensors from false-triggering.

## Wiring Diagram

—This product should be installed by a qualified electrician.

### A. Ceiling mount (HIM98/UH-A)

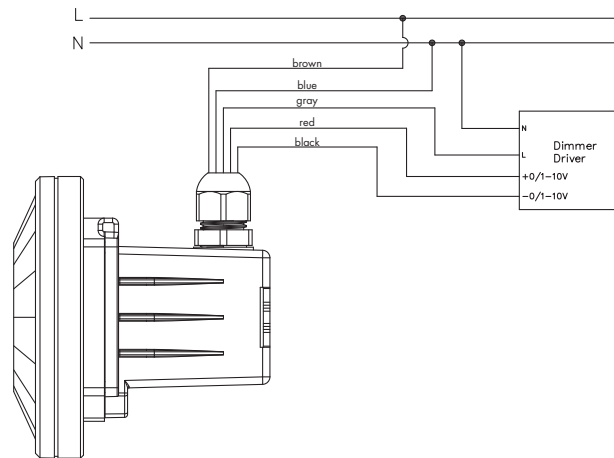

### B. Screw to the Luminaire by conduit (HIM98/UH-B)

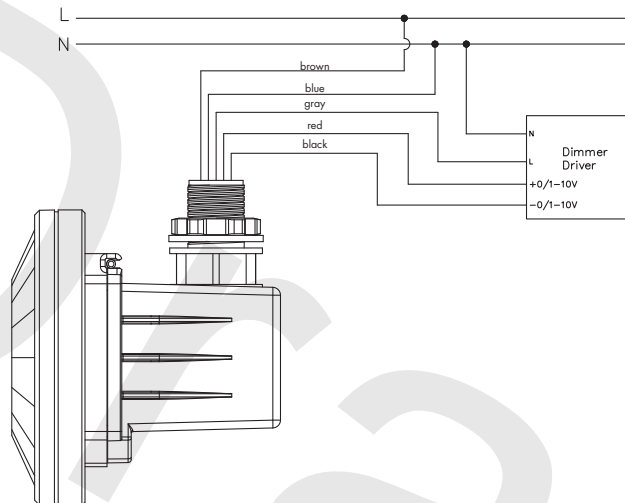

### C. Attach to the shade by clamp (HIM984/UH-C)

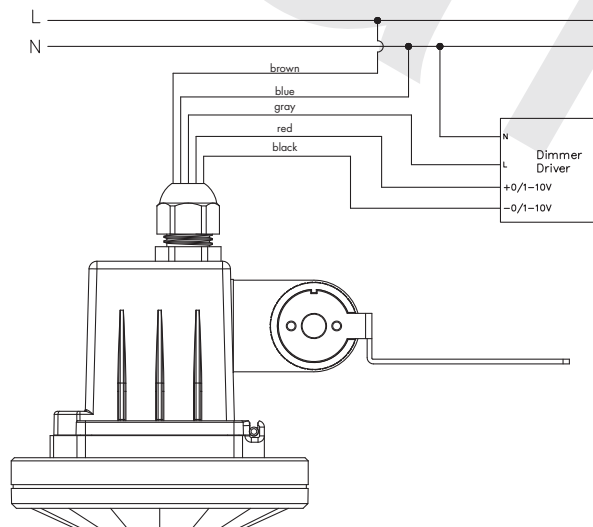

## Detection Pattern

### a. High Frequency (microwave)

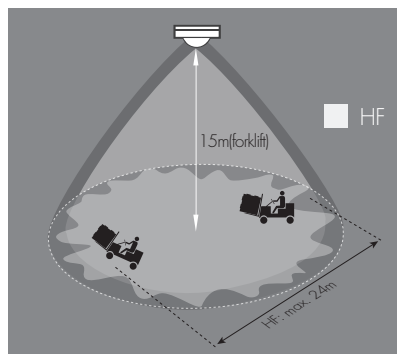

Forklift

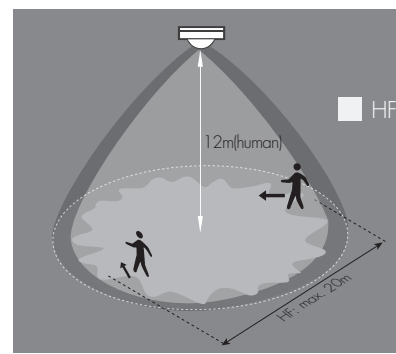

Human

### b. PIR

\*When relative humidity < 65%, storage temperature < 25 °C

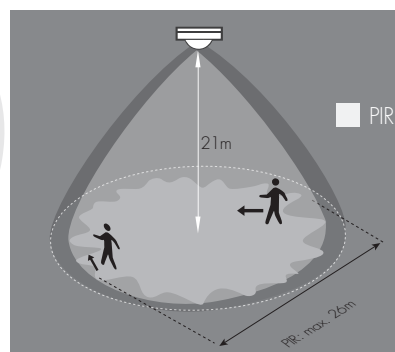

## Dual Sense Introduction

It's commonly known Microwave and Infrared are main detecting technologies in lighting controls. Both have the advantage and disadvantage for industrial applications.

#### Advantage

- \* sensitive to minor motion.
- \* sensitive to radial movement.
- \* can be reflected by objects hence covering big detection area
- \* resilient to heat source, smoke and air conditioner.



#### Advantage

- \* no penetration, confined detection area.
- \* sensitive to tangential movement.
- \* resilient to motion object which has no heat radiation.



#### Disadvantage

- \* penetrates walls, picks up motions outside of the office area;
- \* back wave detection, false trigger by motions at the back.
- \* can be false triggered by ventilation fans, water pipe, elevators etc. in industrial application.

#### Disadvantage

- \* can be false triggered by air conditioner, smoke and other heat sources.

The remedy is to create Dual Sense by combining both technologies to make use of the advantage and bypass the disadvantage.

#### 4 optional detection modes selectable:

- \* HF: Microwave only
- \* PIR: PIR mode only
- \* HF+PIR: both PIR and microwave mode, to decrease the detection capability and detection area. Only when both detections are activated, the motion is considered valid. This is to prevent the sensor from false trigger by heat source, air conditioner, ventilation fans, water pipe and elevators etc...
- \* HF/PIR: either PIR or microwave mode, to increase the detection capability and detection area;

## Shielding Accessory

For the application of limited coverage areas (hallways), the line pattern of the shielding accessory can be freely removed by cutting to achieve a different range of shielding induction, for example, rectangular detection and semi-sphere detection. The portable design also provides an easy installation, which only needs to buckle the shielding accessory onto the lens.

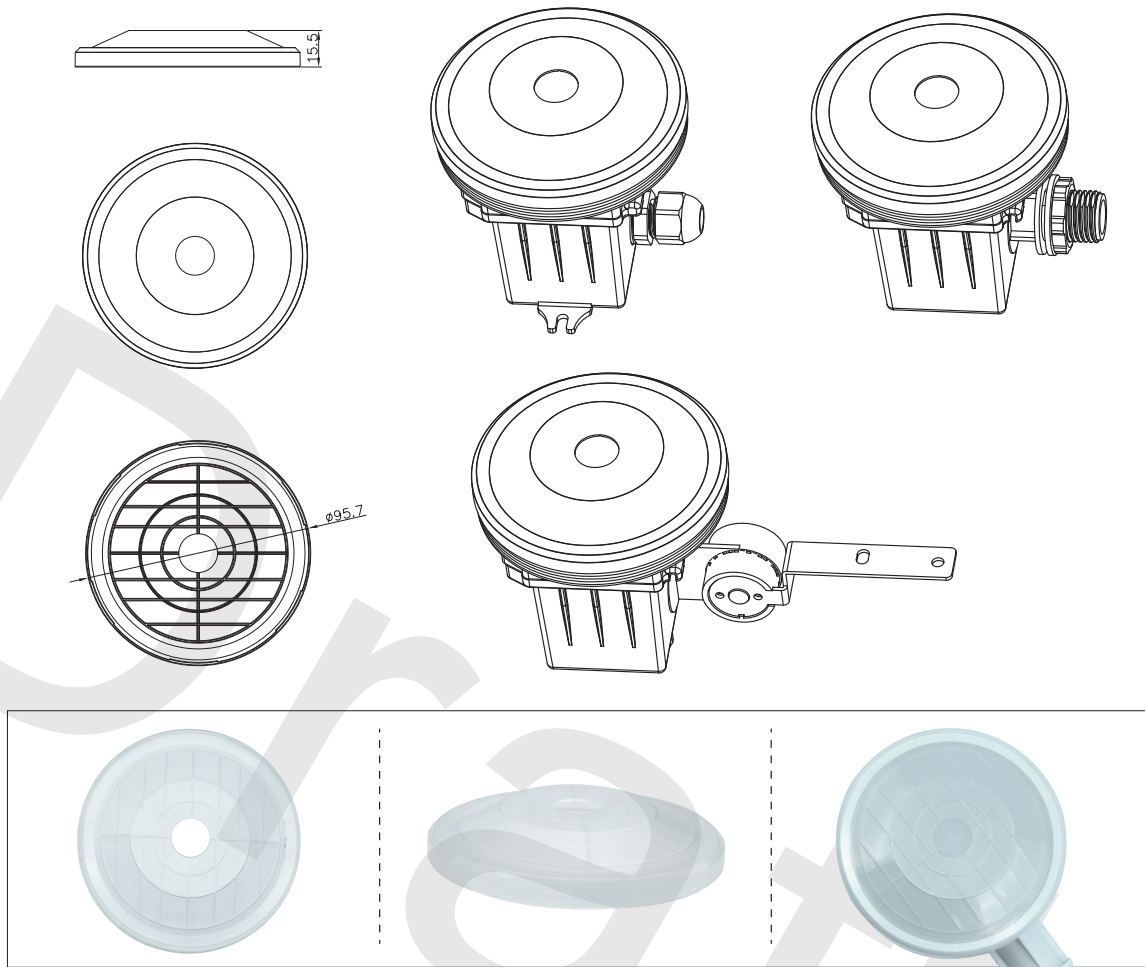

### Placement Guide and Typical Range

#### Smart Phone to Device Range



The smart device with the App installed will have a typical range of 10m, but varies from device to device. During commissioning, the installer will need to be in range of the devices when searching for devices to add to the network.

Once the devices have been added to the network via the App, the devices will start communicating within the wireless mesh. This means that once the network is complete, all devices are accessible from the smart device when in a 20m range of a single point.

## Additional Information / Documents

1. To learn more about detailed product features/functions, please refer to [www.hytronik.com/download ->knowledge ->Introduction of App Scenes and Product Functions](http://www.hytronik.com/download->knowledge->Introduction%20of%20App%20Scenes%20and%20Product%20Functions)
2. Regarding precautions for Bluetooth product installation and operation, please kindly refer to [www.hytronik.com/download ->knowledge ->Bluetooth Products - Precautions for Product Installation and Operation](http://www.hytronik.com/download->knowledge->Bluetooth%20Products%20-%20Precautions%20for%20Product%20Installation%20and%20Operation)
3. Regarding precautions for microwave sensor installation and operation, please kindly refer to [www.hytronik.com/download ->knowledge ->Microwave Sensors - Precautions for Product Installation and Operation](http://www.hytronik.com/download->knowledge->Microwave%20Sensors%20-%20Precautions%20for%20Product%20Installation%20and%20Operation)
4. Regarding precautions for PIR sensor installation and operation, please kindly refer to [www.hytronik.com/download ->knowledge ->PIR Sensors - Precautions for Product Installation and Operation](http://www.hytronik.com/download->knowledge->PIR%20Sensors%20-%20Precautions%20for%20Product%20Installation%20and%20Operation)
5. Data sheet is subject to change without notice. Please always refer to the most recent release on [www.hytronik.com/products/bluetooth technology ->Bluetooth Sensors](http://www.hytronik.com/products/bluetooth%20technology->Bluetooth%20Sensors)
6. Regarding Hytronik standard guarantee policy, please refer to [www.hytronik.com/download->knowledge ->Hytronik Standard Guarantee Policy](http://www.hytronik.com/download->knowledge->Hytronik%20Standard%20Guarantee%20Policy)