

**HIM35**

HF and PIR, Tri-level Control for Independent DALI

**Technical Data**

Input Characteristics

| Model No.      | HIM35                    |
|----------------|--------------------------|
| Mains voltage  | 120~277VAC 50/60Hz       |
| Stand-by power | <1W                      |
| Switched power | Max. 20pcs devices, 40mA |
| Warming-up     | 30s                      |

Sensor Data

| Model No.           | HIM35                            |
|---------------------|----------------------------------|
| Sensor principle    | High Frequency (microwave), PIR  |
| Operation frequency | 5.8GHz +/- 75MHz (HF)            |
| Transmission power  | <0.2mW (HF)                      |
| Sensor mode         | 4 modes: PIR, HF, PIR+HF, PIR/HF |
| Detection range     | Max. (Ø x H) 18m x 15m           |
| Detection angle     | 360°                             |

Safety and EMC

|                       |                               |
|-----------------------|-------------------------------|
| EMC standard (EMC)    | EN55015, EN61000              |
| Safety standard (LVD) | EN60669-1, EN60669-2-1        |
| Radio Equipment (RED) | EN300440, EN301489-1, EN62479 |
| Certification         | Semko, CB, CE, EMC, RED, RCM  |

Environment

|                       |                   |
|-----------------------|-------------------|
| Operation temperature | Ta: -20°C ~ +50°C |
| IP rating             | IP65              |



**Mechanical Structures and Installations**

For more details, please refer to user manual.

A. Ceiling mount (HIM35A)

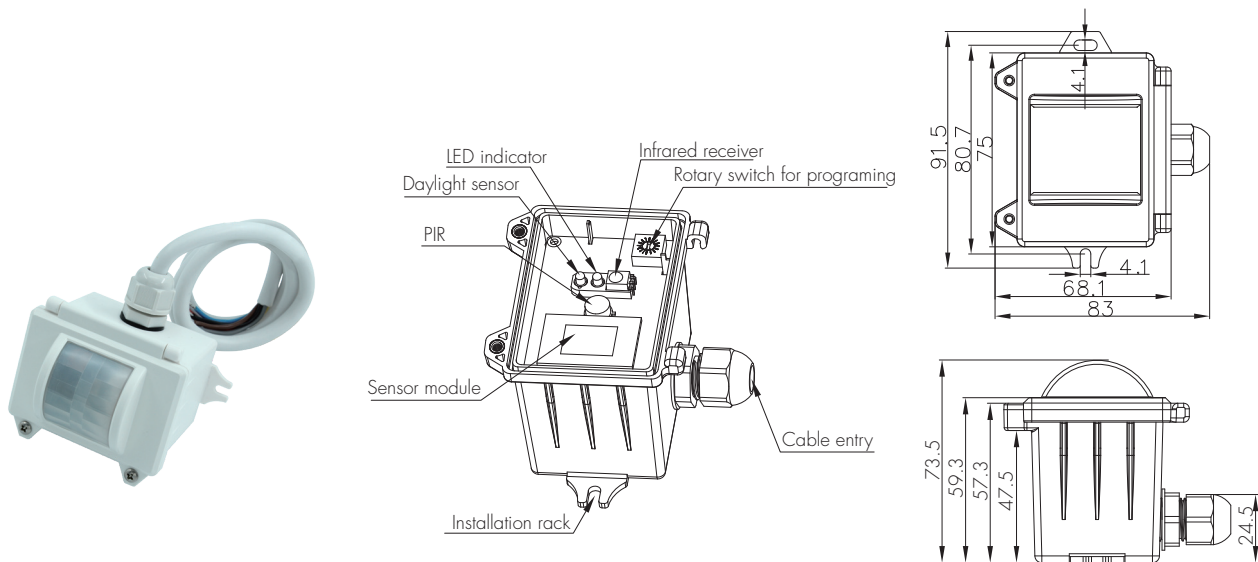

B. Screw to the Luminaire by conduit (HIM35B)

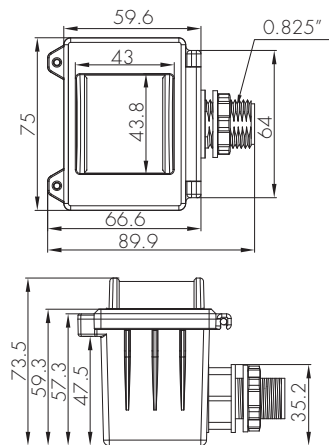
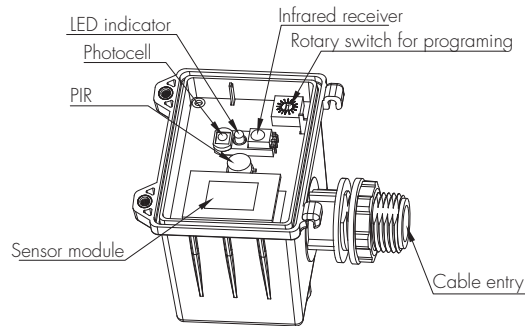

C. Attach to the shade by clamp (HIM35C)

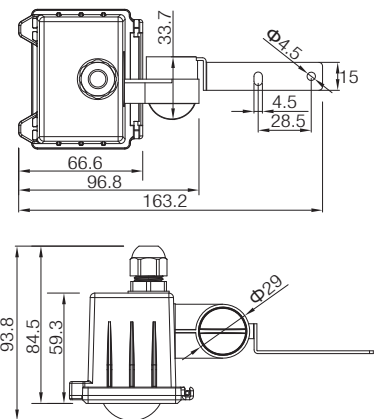
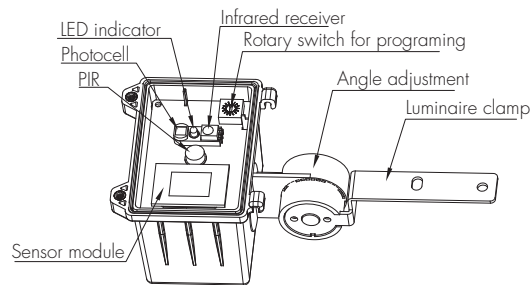

Note: We recommend the mounting distance between sensor to sensor should be more than 2m to prevent sensors from false-triggering.

### Dual Sense Introduction

It's commonly known Microwave and Infrared are main detecting technologies in lighting controls. Both have the advantage and disadvantage for industrial applications.

**Advantage**

- \* sensitive to minor motion.
- \* sensitive to radial movement.
- \* can be reflected by objects hence covering big detection area
- \* resilient to heat source, smoke and air conditioner.



**Advantage**

- \* no penetration, confined detection area.
- \* sensitive to tangential movement.
- \* resilient to motion object which has no heat radiation.



**Disadvantage**

- \* penetrates walls, picks up motions outside of the office area;
- \* back wave detection, false trigger by motions at the back.
- \* can be false triggered by ventilation fans, water pipe, elevators etc. in industrial application.

**Disadvantage**

- \* can be false triggered by air conditioner, smoke and other heat sources.

The remedy is to create Dual Sense by combining both technologies to make use of the advantage and bypass the disadvantage.

4 optional detection modes via remote control:

- \* HF: Microwave only
- \* PIR: PIR mode only
- \* HF+PIR: both PIR and microwave mode, to decrease the detection capability and detection area. Only when both detections are activated, the motion is considered valid. This is to prevent the sensor from false trigger by heat source, air conditioner, ventilation fans, water pipe and elevators etc...
- \* HF/PIR: either PIR or microwave mode, to increase the detection capability and detection area;



## Functions and Features

### 1 Intelligent Photocell (daylight detection prior to motion detection)

The built-in photocell will also automatically turn off the light when the ambient natural light exceeds the programmed lux level for more than 5min, regardless of whether motion is detected or not. This feature can be disabled if it is required that the fixture stays at dimmed level during absence.



With sufficient natural light, the light does not switch on when presence is detected.

With insufficient natural light, the sensor switches on the light automatically when presence is detected.

The sensor switches off the light when natural light is sufficient, even with presence.

*Note: if the stand-by time is preset at "+∞", the fixture never switches off but stays at preset dimming level even when natural light is sufficient.*

### 2 Tri-level Control (Corridor Function)

Hytronik builds this function inside the motion sensor to achieve tri-level control, for some areas which require a light change notice before switch-off. The sensor offers 3 levels of light: 100%→dimmed light (natural light is insufficient) →off; and 2 periods of selectable waiting time: motion hold-time and stand-by period; Selectable daylight threshold and freedom of detection area.

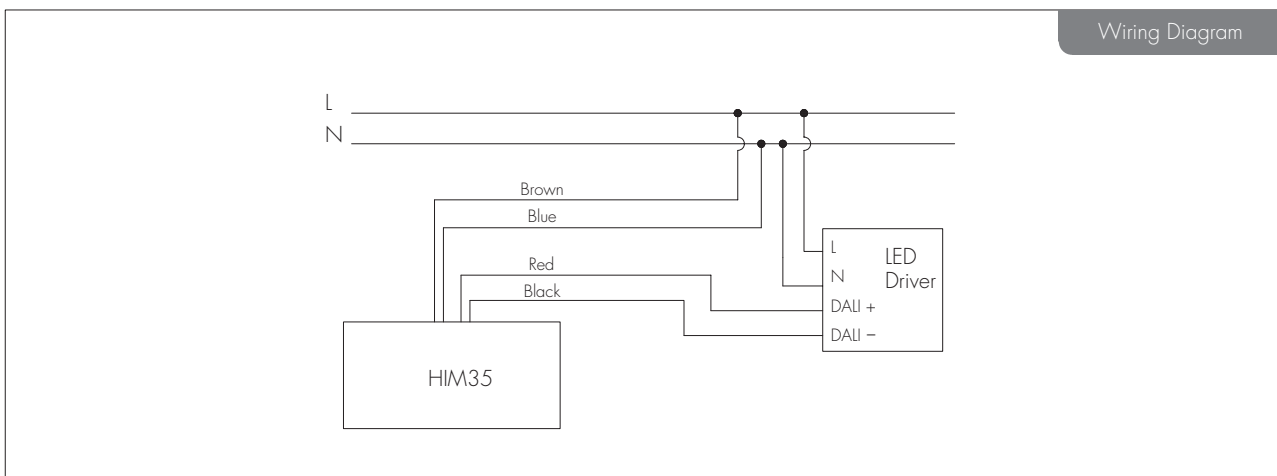

## Detection Pattern

End user can choose the suitable PIR lens in real application to fulfill various requirements. Three options are offered for selection:

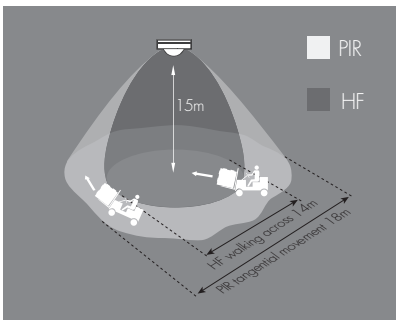

PIR detection: H x D: 15 x 18m (max.)

HF detection: H x D: 15 x 14m (max.)

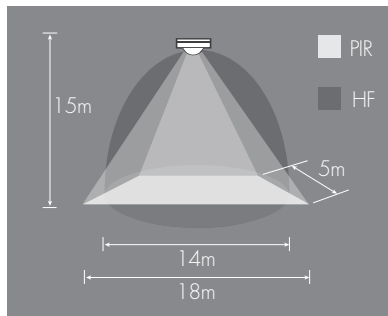

PIR detection: L x W x H: 18 x 5 x 15m (max.)

HF detection: H x D: 15 x 14m (max.)

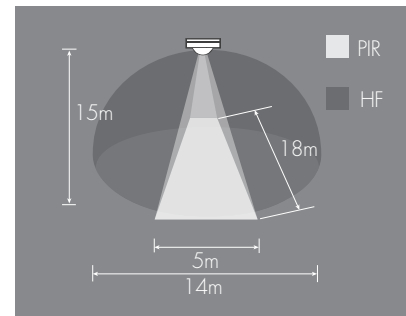

PIR detection: L x W x H: 5 x 18 x 15m (max.)

HF detection: H x D: 15 x 14m (max.)

\* For single person walking across, the detection range is reduced by 1/3.

## Rotary Switch Preset

A rotary switch is built inside the sensor for scene selection / fast programming. Total 16 channels are available:



Rotary switch preset

*Note: settings can also be changed by remote control HRC-11. The last action controls.*

| Channel | Detection range | Hold-time | Daylight sensor | Stand-by time | Stand-by dim level |
|---------|-----------------|-----------|-----------------|---------------|--------------------|
| 0       | 100%            | 5s        | Disable         | 10s           | 10%                |
| 1       | 100%            | 1min      | 2Lux            | 5min          | 10%                |
| 2       | 100%            | 5min      | 10Lux           | 10min         | 10%                |
| 3       | 100%            | 5min      | 30Lux           | 30min         | 10%                |
| 4       | 100%            | 5min      | 10Lux           | 0s            | Disable            |
| 5       | 100%            | 5min      | 30Lux           | +∞            | 10%                |
| 6       | 100%            | 5min      | Disable         | +∞            | 30%                |
| 7       | 100%            | 10min     | 2Lux            | 10min         | 10%                |
| 8       | 100%            | 10min     | 10Lux           | 30min         | 10%                |
| 9       | 100%            | 10min     | 30Lux           | +∞            | 10%                |
| A       | 100%            | 10min     | Disable         | +∞            | 30%                |
| B       | 75%             | 10min     | 30Lux           | +∞            | 10%                |
| C       | 50%             | 10min     | 10Lux           | +∞            | 10%                |
| D       | 100%            | 30min     | 50Lux           | +∞            | 10%                |
| E       | 100%            | 30min     | Disable         | +∞            | 30%                |
| F       | 100%            | 5s        | 2Lux            | 10s           | 10%                |

## Settings (Remote Control HRC-11)



### Permanent ON/OFF function

Press button "ON/OFF" to select permanent ON or permanent OFF mode.

\* Press button "AUTO", "RESET" to quit this mode.

The mode will change to AUTO Mode after power failure.



### Reset Settings

Press button "RESET", all settings go back to rotary switch settings.



### Shift Button

Press button "Shift", the LED on the top left corner is on to indicate mode selection.

All values / settings in RED are valid for 20 seconds.



### AUTO mode

Press button "AUTO" to initiate automatic mode. The sensor starts working and all settings remain as before the light is switched ON/OFF.

Note: "Semi-auto" function is disabled.

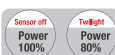

### Power output

Press the buttons to select light output at 80% (at initial 10,000 hours) or 100%.

Note: "Sensor off" and "Twilight" functions are disabled.



### Brightness +/-

Press the buttons to adjust the light brightness during hold-time.



### Scene program - 1-key commissioning

1. Press button "Start" to program.
2. Select the buttons in "Detection range", "Daylight threshold", "Hold-time", "Stand-by time", "Stand-by dimming level" to set all parameters.
3. Press button "Memory" to save all the settings programmed in the remote control.
4. Press button "Apply" to set the settings to each sensor unit(s).

For example, to set detection range 100%, daylight threshold Disable, hold-time 5min, stand-by time +∞, stand-by dimming level 30%, the steps should be: Press button "Start", button "100%", "Disable", "Shift", "5min", "Shift", "+∞", "30%", "Memory". By pointing to the sensor unit(s) and pressing "Apply", all settings are passed on the sensor(s).

### Detection range

Press buttons in zone "Detection range" to set detection range at 100% / 75% / 50% / 10%.

### Daylight threshold

Press buttons in zone "Daylight threshold" to set daylight sensor at 2Lux / 10Lux / 50Lux / 100Lux / 300Lux / 500Lux / Disable.

Note: To set daylight sensor at 100Lux / 300Lux / 500Lux, press "Shift" button first.

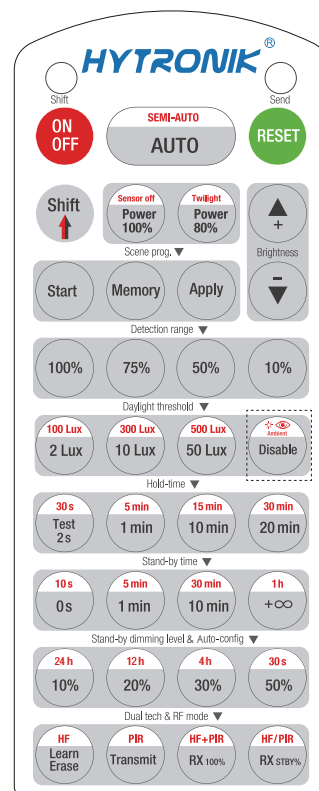

HRC-11

### Load Indication:

The light will flash ONCE rapidly after receiving the command from the remote control successfully.

### Ambient daylight threshold

1. Press button "Shift", the red LED starts to flash.
2. Press button "Ambient", the surrounding lux level is sampled and set as the new daylight threshold.

### Hold-time

Press buttons in zone "hold-time" to set the hold-time at 2s / 30s / 1min / 5min / 10min / 15min / 20min / 30min.

*Note: 1. To set hold-time at 30s / 5min / 15min / 30min, press "Shift" button first.*

*2. 2s is for testing purpose only, stand-by period and daylight sensor settings are disabled in this mode.*

\*To exit from Test mode, press button "RESET" or any button in "Hold-time".

### Stand-by time (corridor function)

Press buttons in zone "stand-by time" to set the stand-by period at 0s / 10s / 1min / 5min / 10min / 30min / 1h / +∞.

*Note: "0s" means on/off control; "+∞" means bi-level control, the fixture is 100% on when there is motion detected, and remains at the stand-by dimming level when no presence after motion hold-time.*

### Stand-by dimming level

Press the button in zone "stand-by dimming level" to set the stand-by dimming level at 10% / 20% / 30% / 50%.

### Auto-configuration function

All buttons in this zone are disabled.

### Dual tech & RF mode

1. Press buttons in this zone to select sensor technology.
  - HF+PIR: the light is on when both HF and PIR sensors are activated.
  - HF/PIR: the light is on when HF or PIR sensors are activated.
2. Learn / Erase, Transmit, RX100% and RX STBY% are disabled.

## Additional Information / Documents

1. Regarding precautions for microwave sensor installation and operation, please kindly refer to [www.hytronik.com/download ->knowledge ->Microwave Sensors - Precautions for Product Installation and Operation](http://www.hytronik.com/download->knowledge->Microwave%20Sensors%20-%20Precautions%20for%20Product%20Installation%20and%20Operation)
2. Regarding precautions for PIR sensor installation and operation, please kindly refer to [www.hytronik.com/download ->knowledge ->PIR Sensors - Precautions for Product Installation and Operation](http://www.hytronik.com/download->knowledge->PIR%20Sensors%20-%20Precautions%20for%20Product%20Installation%20and%20Operation)
3. Regarding Hytronik standard guarantee policy, please refer to [www.hytronik.com/download ->knowledge ->Hytronik Standard Guarantee Policy](http://www.hytronik.com/download->knowledge->Hytronik%20Standard%20Guarantee%20Policy)