

QCB03



* White color housing by default. Black color housing can be supplied upon request.

Key Features

- Dimmable control applications (DALI/DALI-2 or 0/1-10V)
- 8 luminaire outlets + 1 extra sensor outlet for sensor connection
- Luminaire outlet: GST type 6-pole terminal base (L' or L, N, E, Em, Dim+, Dim-)
- Sensor outlet: GST type 8-pole terminal base (L, N, E, L', P1, P2, Dim-, Dim+)
- Black housing and white housing available to choose from
- Freely switch between 1-channel (1 x 8) & 2-channel (2 x 4) control
- Tamper-proof structure design
- Expandable: easy extension to another QCB03 via plug' n' play
- Rating of system: Max 16A. Rating of each output: Max 10A
- Flame-retardant material for safety protection

Ordering data

Model name	Description
QCB03	GST type 6-pole terminal base quick connection box for dimming application, with DALI/DALI-2 or 0/1-10V output, 8 luminaire outlets and 1 sensor outlet. Freely switch between 1-channel and 2-channel control. Rating of system 16A, rating of each output 10A.

Your Benefits

- Five types of installation methods meets different project needs
- Reduce labour hours and labour cost significantly
- Simple and intuitive wiring connections
- Improved safety level during wiring operations
- Clear and clean wiring makes it easy for future maintenance
- Can be supplied with pre-wired cables

Dimensions (mm)

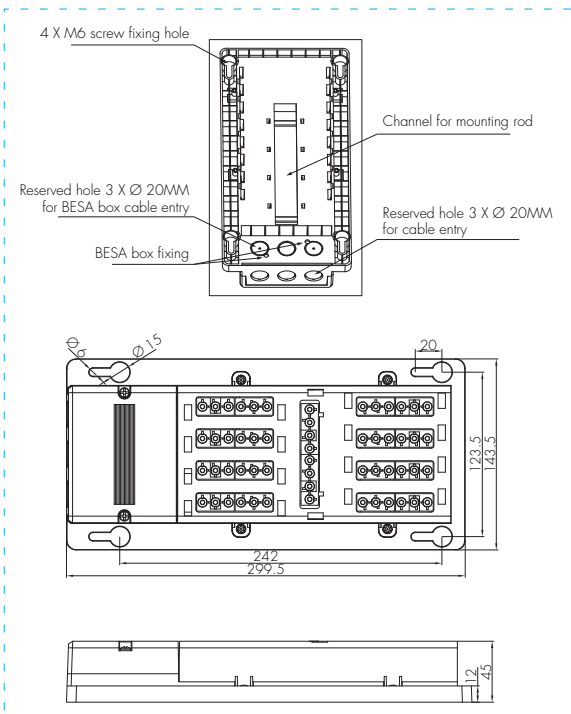

Input & Output Terminal Function

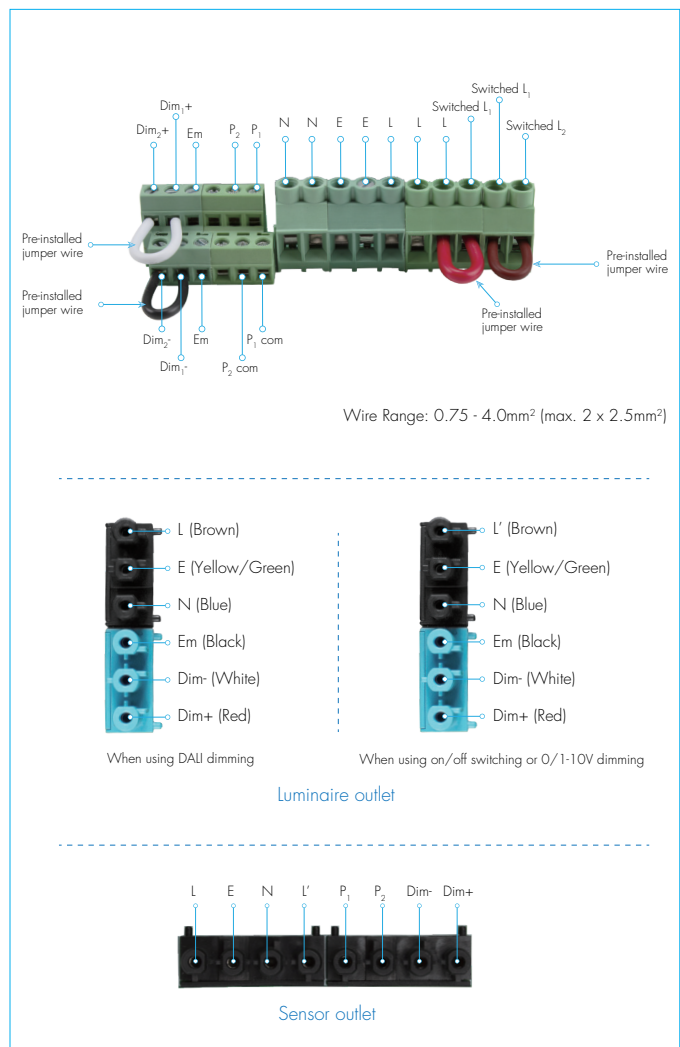

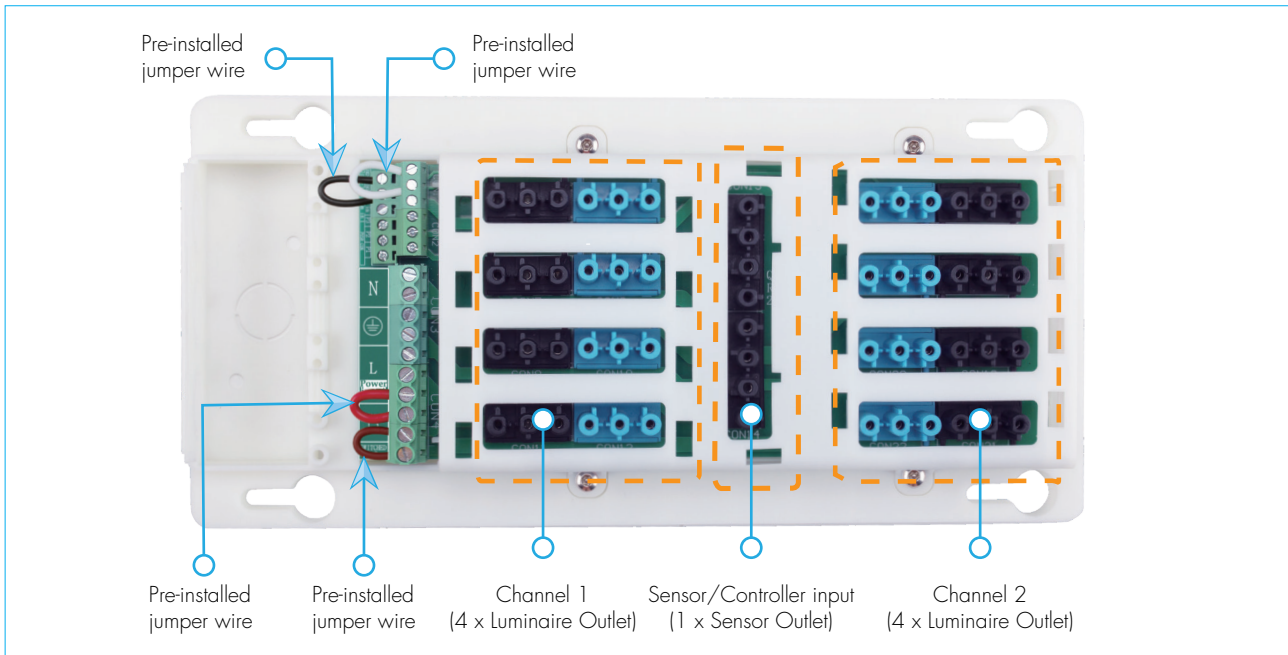

Factory default for QCB03 comes with four pre-installed jumper wires. The brown wire short-connects Switched L1 and Switched L2 together, the red jumper wire short-connects Switched L1 and L, the black jumper wire short-connects Dim₁₋ and Dim₂₋, and the white jumper wire short-connects Dim₁₊ and Dim₂₊. With these jumper wires, user can freely choose different dimming control method and also freely switch between one-channel and two-channel control.

- 1) one-channel (1 x 8) DALI dimming --- keep all four jumper wires.
- 2) two-channel (2 x 4) dual DALI dimming --- keep red wire & brown wire, remove black wire & white wire.
In this case the two channels will be controlled separately (channel 1 is controlled by Dim₁₊ & Dim₁₋, and channel 2 is controlled by Dim₂₋ & Dim₂₊).
- 3) one-channel (1 x 8) 0/1-10V dimming --- remove red wire, keep brown wire & black wire & white wire.
- 4) two-channel (2 x 4) dual 0/1-10V dimming --- remove all four jumper wires.
In this case the two channels will be controlled separately (channel 1 is controlled by Switched L1, Dim₁₊ & Dim₁₋, and channel 2 is controlled by Switched L2, Dim₂₋ & Dim₂₊).
- 5) two-channel (2 x 4) DALI dimming + on/off switching --- keep red wire, remove brown wire & black wire & white wire.
In this case the two channels will be controlled separately (channel 1 is controlled by Dim₁₊ & Dim₁₋, and channel 2 is controlled by Switched L2).
- 6) two-channel (2 x 4) 0/1-10V dimming + on/off switching --- remove all four jumper wires.
In this case the two channels will be controlled separately (channel 1 is controlled by Dim₁₊ & Dim₁₋, and channel 2 is controlled by Switched L2).

This flexible design aims to reduce model inventories for users, and just one box is capable enough to handle different dimming requirements on the project site. Easy for management, and powerful for usage!