

## Product Description

GST type 6-pole terminal base quick connection box for dimming application, with DALI or 0/1-10V output, 12 luminaire outlets and 2 sensor outlet. Freely switch between one-channel and two-channel control. Rating of system 16A, rating of each output 10A.



## Key Features

- Dimmable control applications (DALI-2 or 0/1-10V)
- 12 luminaire outlets + 2 extra sensor outlet for sensor connection
- Luminaire outlet: GST type 6-pole terminal base (L or L', E, N, Em, Dim-, Dim+)
- Sensor outlet: GST type 8-pole terminal base (L, E, N, L', P1, P2, Dim-, Dim+)
- Black housing and white housing available to choose from
- Freely switch between one-channel (1X12) & two-channel (2X6) control
- Tamper-proof structure design
- Expandable: easy extension to another QCB03/ECO via plug' n' play
- Rating of system: Max 16A. Rating of each output: Max 10A
- Flame-retardant material for safety protection

## Your Benefits

- Five types of installation methods meets different project needs
- Reduce labour hours and labour cost significantly
- Simple and intuitive wiring connections
- Improved safety level during wiring operations
- Clear and clean wiring makes it easy for future maintenance
- Can be supplied with pre-wired cables

## Technical Specifications

Mains voltage	220~240VAC 50/60Hz
Rated load	Rating of system 16A. Rating of each output 10A
Terminal capacity	0.75 - 4.0m <sup>2</sup> (max. 2 x 2.5m <sup>2</sup> )
Storage temperature	-20°C ~ +60°C
Max. relative humidity	20 ~ 90%
Insulation	Class II

# Mechanical Structure & Dimensions

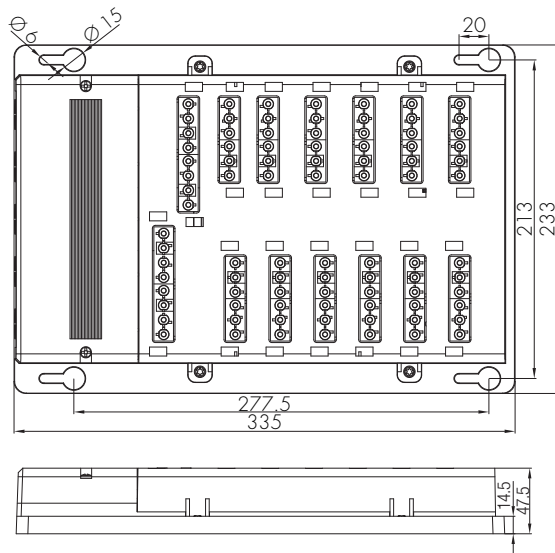
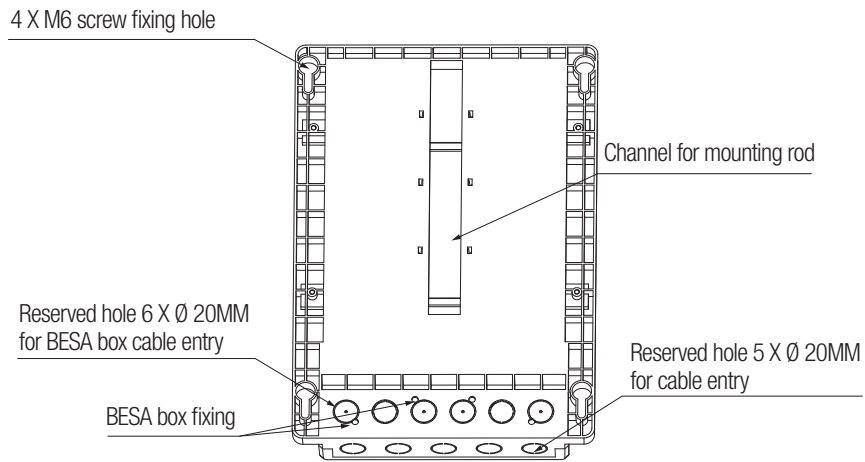

# Input & Output Terminal Function

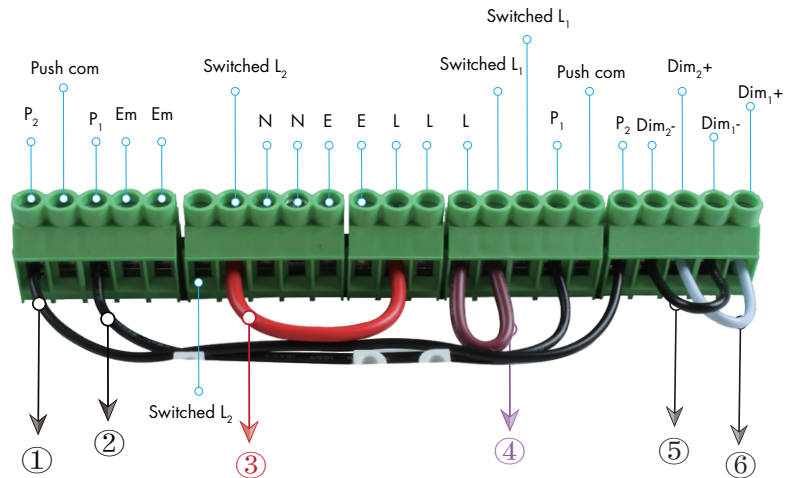

Wire Range: 0.75 - 4.0mm<sup>2</sup> (max. 2 x 2.5mm<sup>2</sup>)

## Luminaire outlet

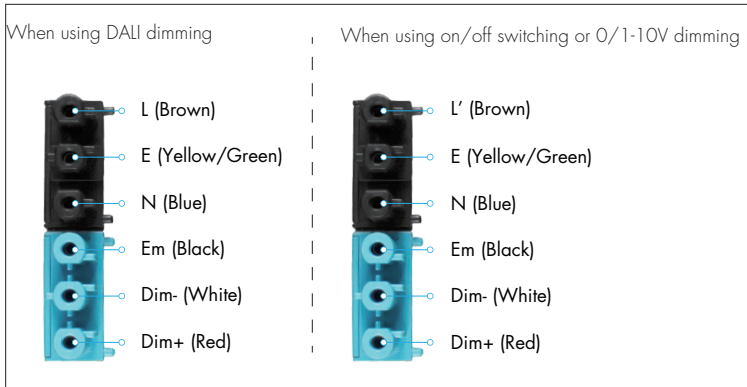

## Sensor outlet

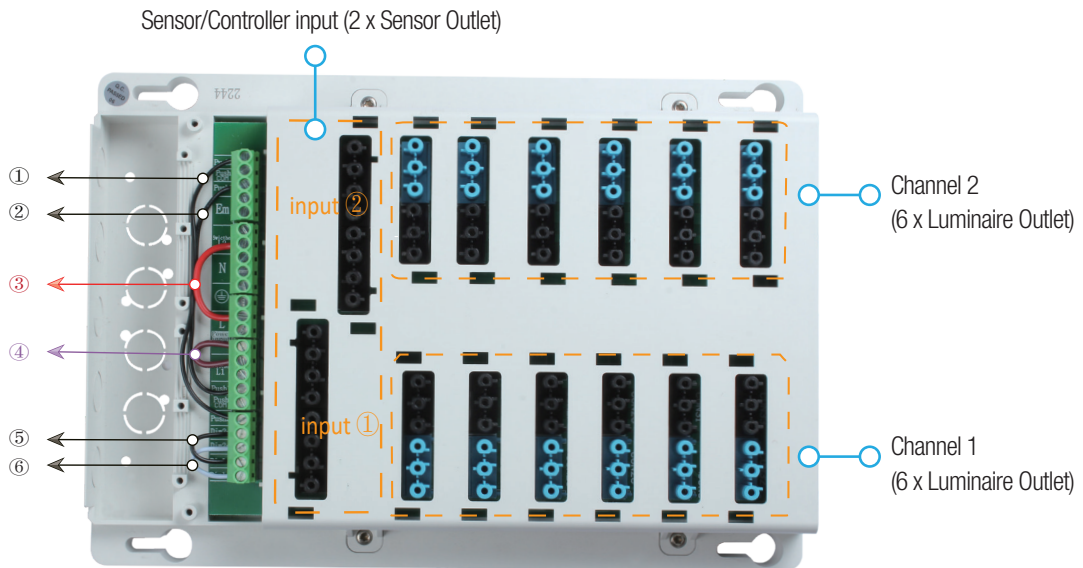
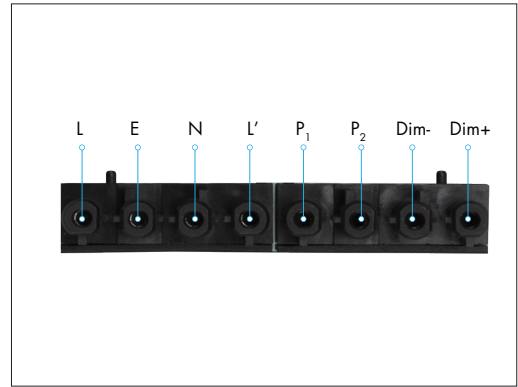

Factory default for QCB03/ECO comes with six pre-installed jumper wires. The wire ① short-connects Push 2, the wire ② short-connects Push 1, the wire ③ short-connects Switched L2 and L, the wire ④ short-connects Switched L1 and L together, the wire ⑤ short-connects Dim2- and Dim1-, and the jumper wire ⑥ short-connects Dim2+ and Dim1+. With these jumper wires, user can freely choose different dimming control method and also freely switch between one-channel and two-channel control.

- 1) one-channel / one sensor (1 x 12) DALI dimming --- remain all jumper wires connected.
- 2) two-channel / two sensor (2 x 6) dual DALI dimming --- remain wire ③ & wire ④, remove wire ①, ②, ⑤ and ⑥.  
In this case the two channels will be controlled separately (channel 1 is controlled by Dim1+ & Dim1-, and channel 2 is controlled by Dim2- & Dim2+).
- 3) one-channel / one sensor (1 x 12) 0/1-10V dimming --- remove wire ④, remain the other jumper wires connected.
- 4) two-channel / two sensor (2 x 6) dual 0/1-10V dimming --- remove all jumper wires.  
In this case the two channels will be controlled separately (channel 1 is controlled by Switched L1, Dim1+ & Dim1-, and channel 2 is controlled by Switched L2, Dim2- & Dim2+).
- 5) two-channel / two sensor (2 x 6) DALI dimming + on/off switching --- remain wire ④, remove the other jumper wires.  
In this case the two channels will be controlled separately (channel 1 is controlled by Dim1+ & Dim1-, and channel 2 is controlled by Switched L2).
- 6) two-channel / one sensor (2 x 6) DALI dimming + on/off switching (eg. HBIR29/2CH)  
--- remain wire ③, ⑤, ⑥, remove the other jumper wires.  
In this case, the sensor need to be plugged into input 1. The two channels will be controlled separately (channel 1 is controlled by Dim1+ & Dim1-, and channel 2 is controlled by Switched L2).
- 7) two-channel / two sensor (2 x 6) DALI dimming + 0/1-10V dimming --- remain wire ④, remove the other jumper wires.  
In this case the two channels will be controlled separately. Channel 1 is controlled by DALI (Dim1+ & Dim1-), and channel 2 is controlled by (0/1-10V) Switched L2.

This flexible design aims to reduce model inventories for users, and just one box is capable enough to handle different dimming requirements on the project site. Easy for management, and powerful for usage!

## Installation methods

### Surface Mount ▼

It can work with 4 x M6 screws to fix onto both walls and ceilings.

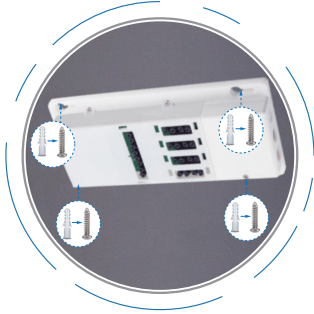

### BESA/Junction Box Connection ▼

It can be connected with BESA/junction box.

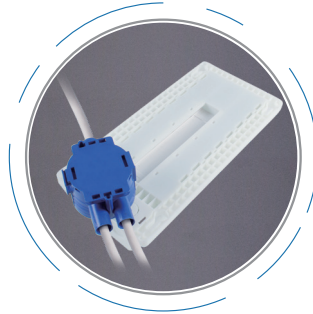

### Channel Nut Mount ▼

It can work with channel nuts to fasten into the back.

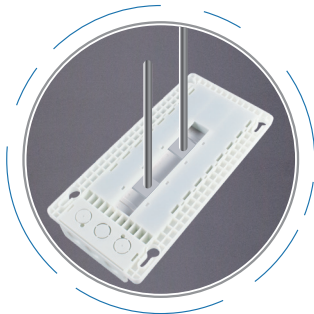

### Mounting Rods ▼

It can be fixed with mounting rods.



### Marco Tray Mount ▼

It can work with Marco clips steel wire cables tray system.

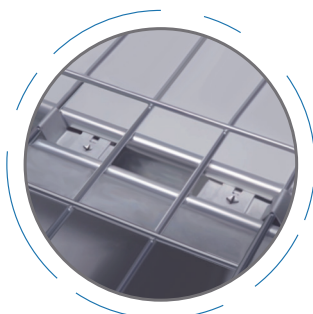

---

## Minimum Installation Height

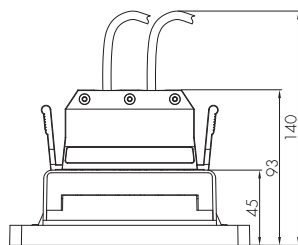

Sensor plug (HPO6)

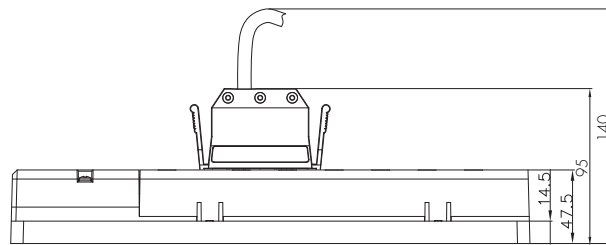

Luminaire plug (HPO3)

Note: The minimum height for total height of unit is 140mm(including connectors and cables).

## Wiring Diagram

This product should be installed by a qualified electrician.

Factory default setting with a pre-installed jumper wire One-channel (1x12) dimming control

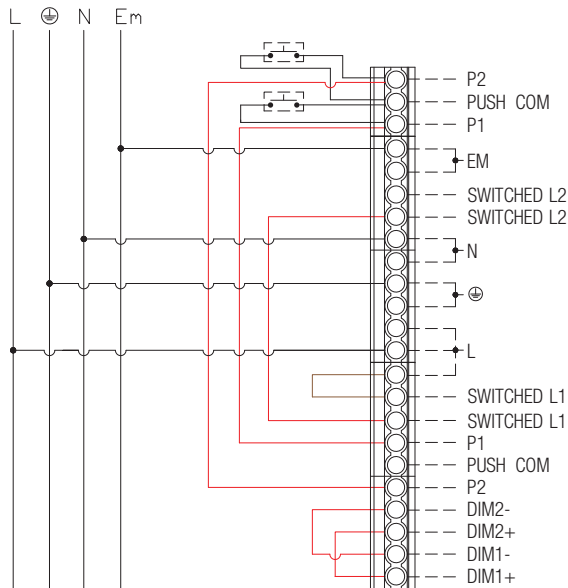

Note: 1. For two-channel (2X6) switching control please remove the jumper wire.  
2. Do not wire across phases.

## Wiring & Emergency Test

Local lighting switch and local emergency test switch

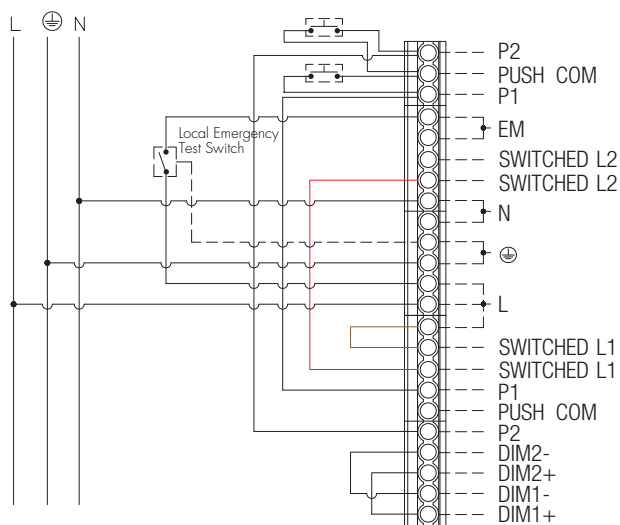

Note: Do not wire across phases.

## Using Local lighting switch for power interruption

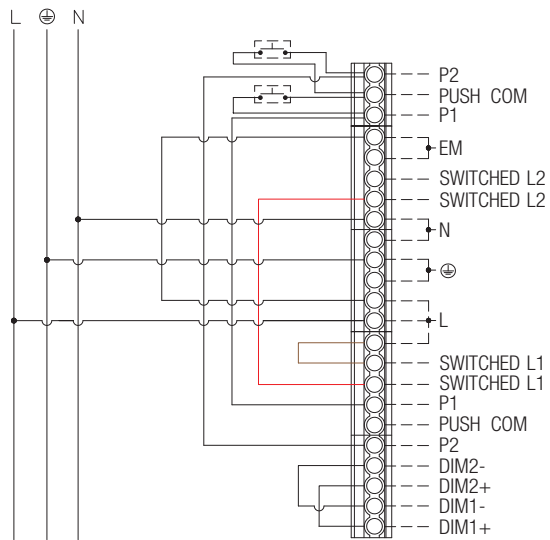

- Note: 1. A local lighting switch may still be used when there is a central emergency test switch or when a circuit breaker is used to interrupt the power.  
2. Do not wire across phases.

## Emergency test using central switch

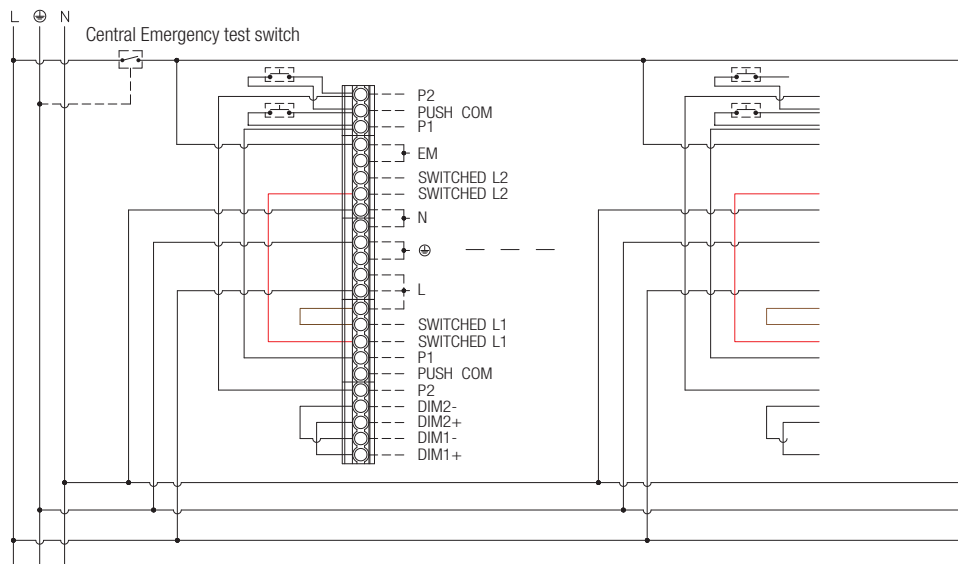

- Note: 1. A local lighting switch may still be used when there is a central emergency test switch.  
2. Do not wire across phases.

## Ceiling Rose/ Conduit Box Connection

### Description

Ceiling rose QCCR01 can be used when there is a need to take power from a conduit box. The installation-friendly design comes with a very spacious termination space for really easy wirings.

### Key Features

- Can be freely placed or fixed with BESA/junction box
- Taking power from BESA/junction box
- 4-pole GST type connector
- Allowing fast connection with quick connection box
- 15mm depth big cabling space
- 48-68mm pitch for conduit mounting
- Nominal current max. 16A
- Flame-retardant material for safety protection

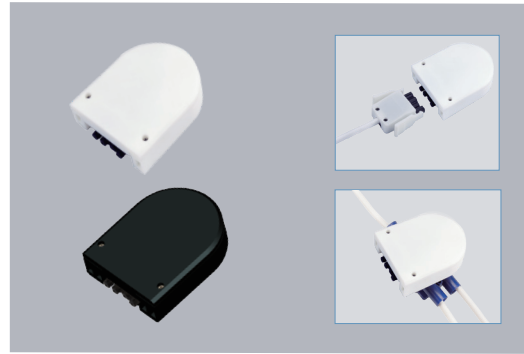

\*QCCR01 is supplied with white color housing by default. Black color housing can be supplied upon request.

### Mechanical Structure & Dimensions

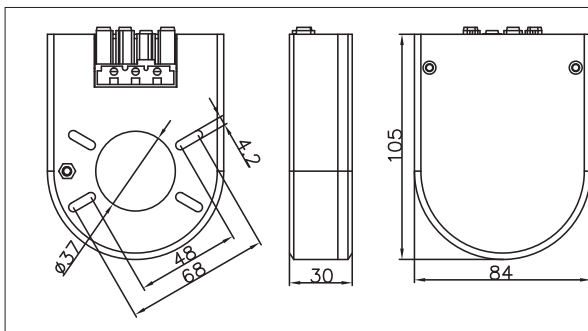

### Input & Output Terminal Function

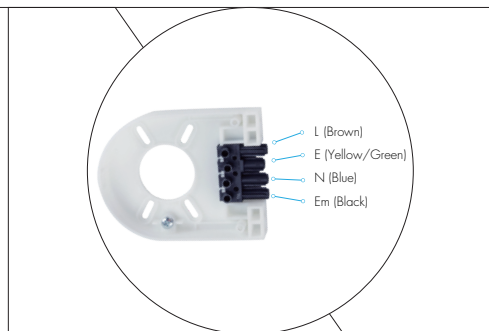

### Secure [QCB03/ECO] with BESA/Junction box

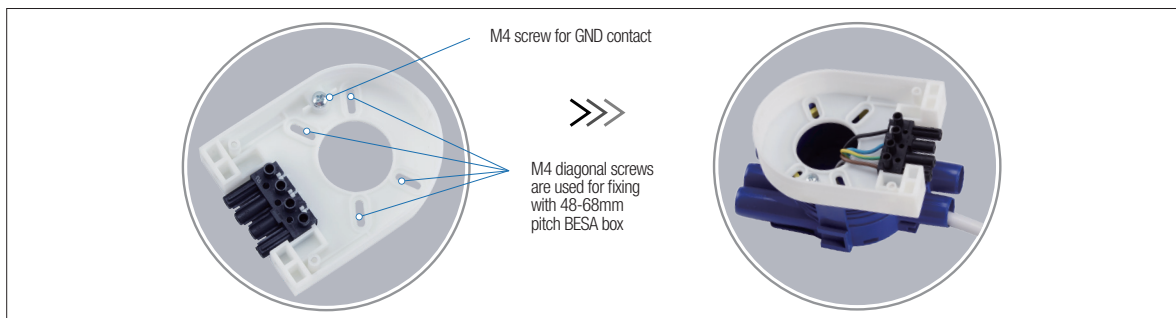

### Connection to QCB03/ECO

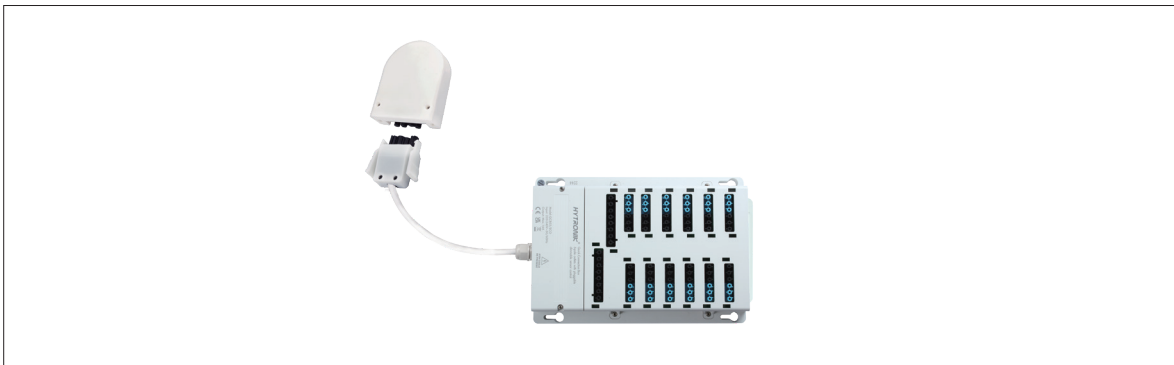

### Additional Information / Documents

1. Regarding Hytronik standard guarantee policy, please refer to [www.hytronik.com/download ->knowledge ->Hytronik Standard Guarantee Policy](http://www.hytronik.com/download->knowledge->Hytronik%20Standard%20Guarantee%20Policy)