

IP65 High Bay HF Motion Sensor

HYTRONIK®

HMW38/RF
1-10V Dimming with RF Wireless Transmission

Technical Data

Input Characteristics

Model No.	HMW38/RF
Mains voltage	220~240VAC 50/60Hz
Stand-by power	< 1.5W
Rated load	Capacitive: 800VA Resistive: 1000W
HC034RF (IP20)	400VA (capacitive); 1200W (resistive)
Warming-up	20s

Safety and EMC

EMC standard (EMC)	EN55015, EN61000
Safety standard (LVD)	EN60669-1, EN60669-2-1
Radio Equipment (RED)	EN300440, EN301489-1, EN62479
Certification	Semko, CB, CE, EMC, RED, RCM

Sensor & RF Data

Model No.	HMW38/RF
Sensor principle	High Frequency (microwave)
Operation frequency	5.8GHz +/- 75MHz
Transmission power	< 0.2mW
Detection range	Installation Height : 20m (forklift) 15m (person) Detection Range (Ø) : 20m
Detection angle	360°
RF frequency	868MHz (FSK mode)
RF transmission distance	30m indoor, 50m outdoor

Environment

Operation temperature	Ta: -20°C ~ +50°C
IP rating	IP65







CB IP65

Mechanical Structures and Installations

For more details, please refer to user manual.

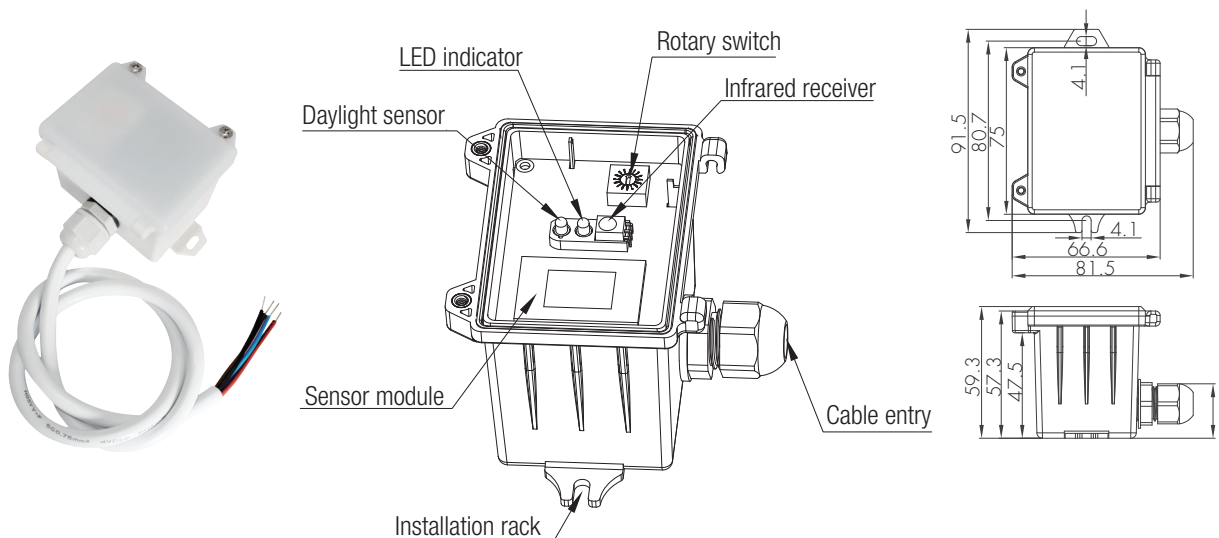
A. Ceiling mount



B. Screw to the Luminaire by conduit

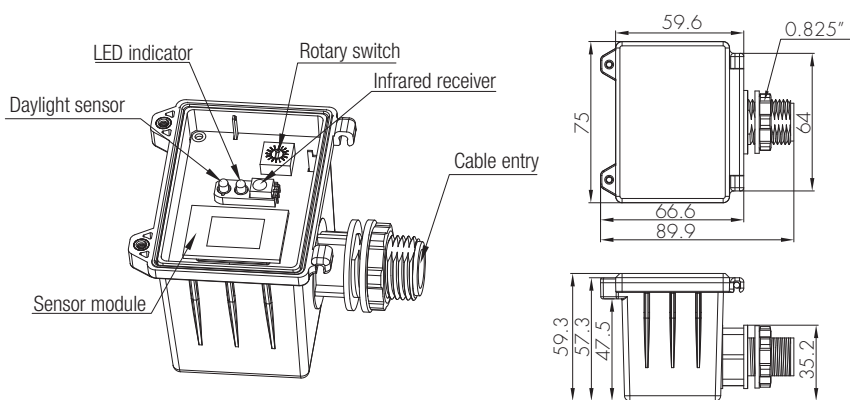

C. Attach to the shade by clamp

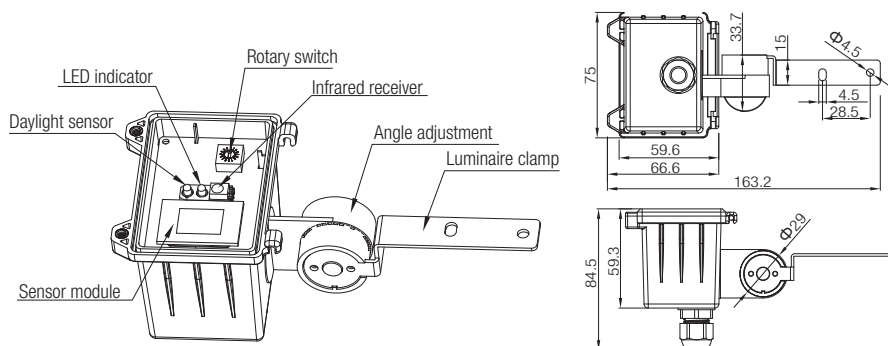

The motion detected by the master unit HMW38/RF passes to all other units programmed on the same group via RF transmission. The transmission can reach 30 meters indoor and 50 meters in open areas. A daylight sensor is also built-in to prevent the light switching on when surrounding natural light is sufficient.

Note: We recommend the mounting distance between sensor to sensor should be more than 4m to prevent sensors from false-triggering.

RF receiver serves as slave only, which turns on the light after receiving the RF "ON" signal from the master.

HC034RF (1-10V output, RF grouping by rotary switch or remote control)

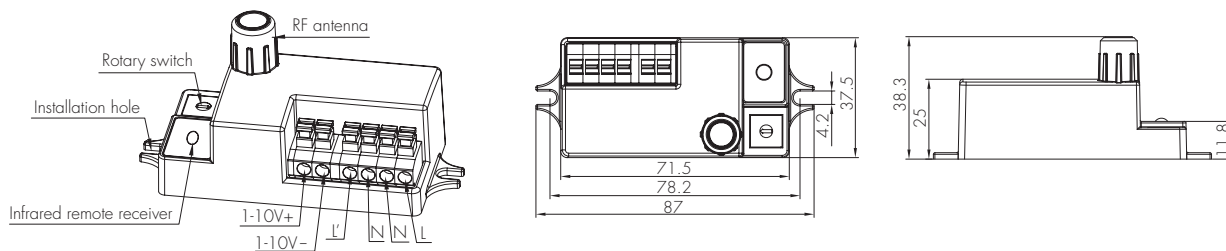

Distance Recommended between Sensors

Pay attention: The RF signal could be affected by big metal plate & wireless devices such as GSM mobile antenna, strong Wifi signal, ultra high-voltage cable which emits frequent electromagnetic waves radiation, which may interfere with the RF transmission and communication! Please always check the application environment before mass installation!

We recommend the mounting distance between sensors to be more than 6m to avoid sensors from being false-triggered.

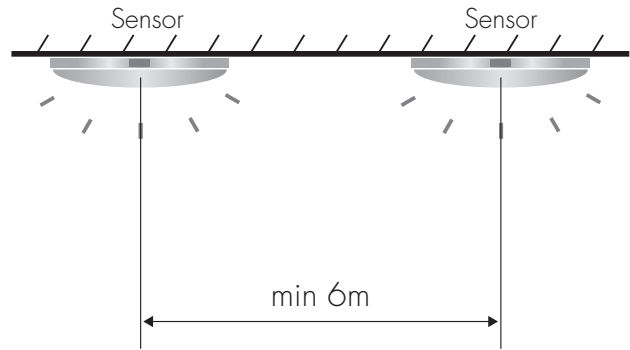

Functions and Features

1 Tri-level Control (Corridor Function)

Hytronik builds this function inside the motion sensor to achieve tri-level control, for some areas which require a light change notice before switch-off. The sensor offers 3 levels of light: 100%-->dimmed light (natural light is insufficient) -->off; and 2 periods of selectable waiting time: motion hold-time and stand-by period; Selectable daylight threshold and freedom of detection area.

2 Intelligent Photocell (daylight detection prior to motion detection)

The built-in photocell will also automatically turn off the light when the ambient natural light exceeds the programmed lux level for more than 5min, regardless of whether motion is detected or not. This feature can be disabled if it is required that the fixture stays at dimmed level during absence.

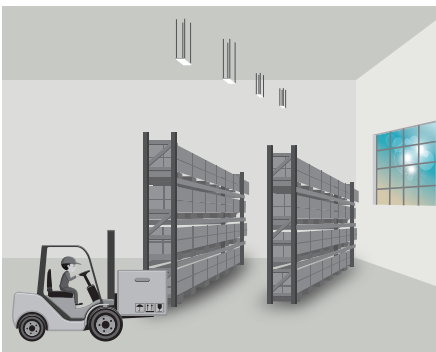

With sufficient natural light, the light does not switch on when presence is detected.



With insufficient natural light, the sensor switches on the light automatically when presence is detected.



The sensor switches off the light when natural light is sufficient, even with presence.

Note: if the stand-by time is preset at "+∞", the fixture never switches off but stays at preset dimming level even when natural light is sufficient.

3 Zero-cross Relay Operation

Designed in the software, sensor switches on/off the load right at the zero-cross point, to ensure that the in-rush current is minimised, enabling the maximum lifetime of the relay.

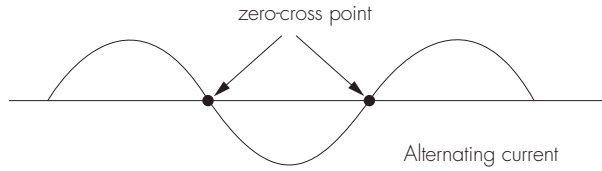

RF Grouping by Rotary Switch (Maximum 15 channels)

15 channels are available for fast grouping via rotary switch on both HMW38/RF and the receiver HC034RF. Simply selecting the same channel on each unit, the grouping is automatically completed.

Noted: channel "0" is not for fast grouping, and sensors can only be grouped by remote control.

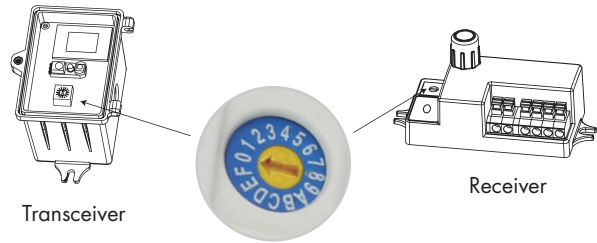

Typical Applications

1 For warehouse (HMW38/RF as both transmitter and receiver)

Settings on this demonstration:

Detection range: 100% Hold-time: 10min Daylight threshold: 100lux Stand-by dimming level: 30% Stand-by period: 10min RX: STBY%

Night

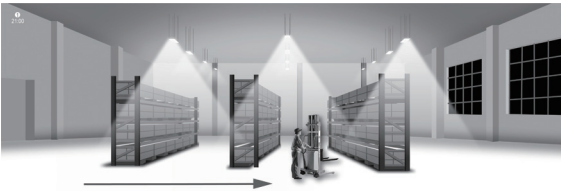

Daytime

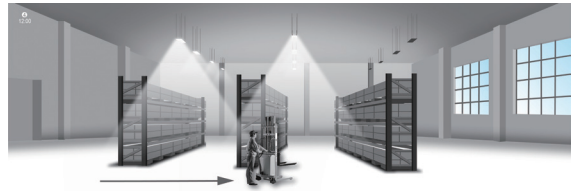

Settings (Remote Control HRC-11)

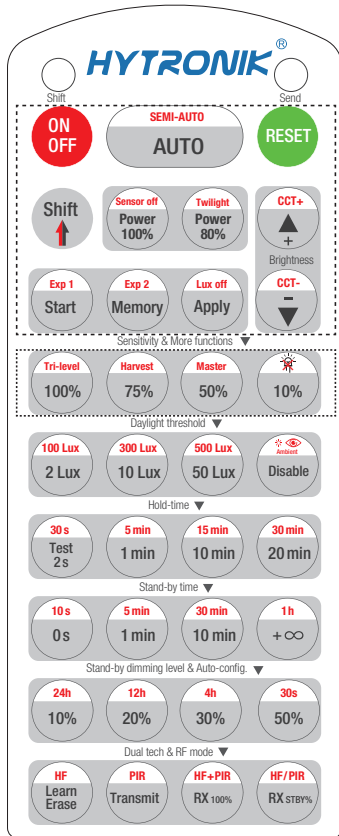

HRC-11

	Press button "ON/OFF" to select permanent ON or permanent OFF mode. * Press button "AUTO"/"RESET" to exit this mode.
	Press button "RESET", perform DIP Switch/Rotary Switch settings. The default settings are: Auto mode; Detection range:100%; Hold time: 1 min; Stand-by time:5min; Stand-by dimming level:20%; Daylight sensor disable; RX 100%.
	Press button "Shift", the LED on the top left corner is on to indicate mode selection. All values / settings in RED are valid for 20 seconds.
AUTO	Press button "AUTO" to initiate automatic mode. The sensor starts working and all settings remain as before the light is switched ON/OFF;
SEMI-AUTO	This key is not applicable on this product.
Power 100% 80%	Press buttons in zone "Power out" to select the light output at 80% (at initial 10,000 hours) or 100%.
Sensor off Twilight	This key is not applicable on this product.
	Press these two buttons to adjust the light output brightness and set a new target lux level. The daylight sensor can measure ambient daylight level and ignore the LED light, so as to calculate how much artificial light is needed to maintain the target lux level.
CCT+ CCT-	This key is not applicable on this product.
Start Memory Apply	<ol style="list-style-type: none"> 1. Press button "Start" to program. 2. Select the buttons in "Detection range", "Daylight threshold", "Hold-time", "Stand-by time", "Stand-by dimming level" to set all parameters. 3. Press button "Memory" to save all the settings programmed in the remote control. 4. Press button "Apply" to set the settings to each sensor unit(s). <p><i>For example, to set detection range 100%, daylight threshold Disable, hold-time 5min, stand-by time +∞, stand-by dimming level 30%, the steps should be: Press button "Start", button "100%", "Disable", "Shift", "5min", "Shift", "+∞", "30%", "Memory". By pointing to the sensor unit(s) and pressing "Apply", all settings are passed on the sensor(s).</i></p>
Lux off	This key is not applicable on this product.
Exp 1 Exp 2	"Exp" refer to Expansion, these two buttons are reserved functions and pending future development.
Sensitivity & More functions	
100% 75% 50% 10%	In AUTO modes, press buttons in zone "Detection range" to set detection range at 100%/75%/50%/10%.
Tri-level Harvest	This key is not applicable on this product.
Master	This key is not applicable on this product.

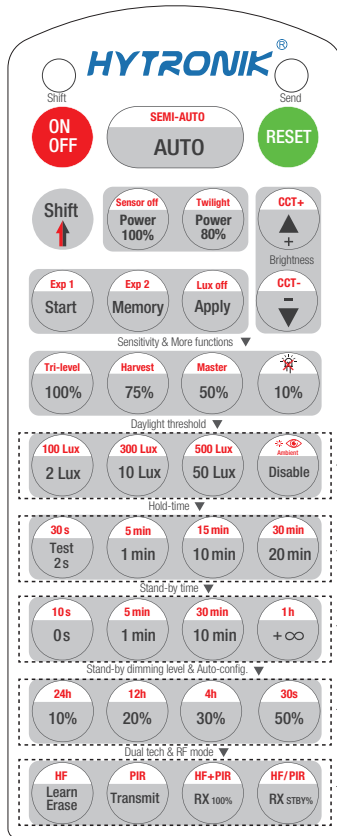

HRC-11

Daylight threshold	
<p>2 Lux 100 Lux 10 Lux 300 Lux 50 Lux 500 Lux Disable</p>	<p>Press buttons in zone "Daylight threshold" to set daylight sensor at 2Lux/ 10Lux / 50Lux / 100Lux / 300Lux/500Lux / Disable. <i>Note: To set daylight sensor at 100Lux / 300Lux/500Lux , press "Shift" button first.</i></p>
<p> Ambient</p>	<p>1. Press button "Shift", the red LED on. 2. Press button "Ambient", the surrounding lux level is sampled and set as daylight threshold / target Lux level.</p>
Hold-time mode	
<p>Test 30 s 2s 1 min 5 min 10 min 15 min 20 min 30 min</p>	<p>In AUTO modes, press buttons in zone "hold-time" to set the hold-time at 2s / 30s / 1min / 5min / 10min / 15min / 20min / 30min. <i>Note: 1. To set hold-time at 30s / 5min / 15min / 30min, press "Shift" button first. 2. 2s is for testing purpose only, stand-by period and daylight sensor settings are disabled in this mode.</i> <i>*To exit from Test mode, press button "RESET" or any button in "Hold-time".</i></p>
Stand-by time mode	
<p>0s 10 s 1 min 5 min 10 min 30 min +∞ 1 h</p>	<p>Press buttons in zone "stand-by time" to set the stand-by period at 0s / 10s / 1min / 5min / 10min / 30min / 1h / +∞. <i>Note: 1. To set stand-by-time at 10s/ 5min / 30min / 1h, press "Shift" button first. 2. "0s" means on/off control; 3. "+∞" means bi-level control, the fixture is 100% on when there is motion detected, and remains at the stand-by dimming level when no presence after motion hold-time. Only when the stand-by time is set in "+∞" and the ambient lux level is below the target lux level, the lux will auto-on.</i></p>
Stand-by dimming level & Auto-config.	
<p>10% 20% 30% 50%</p>	<p>Press the button in zone "stand-by dimming level" to set the stand-by dimming level at 10% / 20% / 30% / 50%.</p>
<p>24h 12h 4h 30s</p>	<p>This key is not applicable on this product.</p>
Dual tech & RF mode	
<p>Learn Erase Transmit</p>	<p>Short press "learn/erase" button to activate pairing mode, then press "transmit" on a primary mode and all the receiver modules will beep 3 times in 1s to indicate the success of pairing. Long press the "learn/erase" button for 3s will erase all the commands received previously.</p>
<p>RX 100% RX STBY%</p>	<p>Press button RX100%, the light on receiver unit is 100% upon receiving RF on signal; Press button "RX STBY%", the light(s) goes to pre-set stand-by dimming level directly.</p>
<p>HF PIR HF+PIR HF/PIR</p>	<p>This key is not applicable on this product.</p>

RF grouping by HRC-11

Short press "Learn/Erase" button on RC to activate pairing mode, and the receiver unit starts to beep once every second for 3min.

Note: up to 30 units can be paired.



Short press "Transmit" button on RC, the commander unit (master unit) beeps one time to send the transmission signal.

Upon receiving the transmission signal, the receiver unit (slave unit) rapidly beeps 3 times in 1s to indicate the success of pairing. Repeat this step to pair more units.

One more short press on "Learn/Erase" button to the receiver unit to complete the pairing process, the receiver unit will quit the pairing mode.

Note: Press button RX100%, the light on receiver unit is 100% on upon receiving RF on signal; Press "RX STBY%" button, the light(s) goes to preset stand-by dimming level directly.

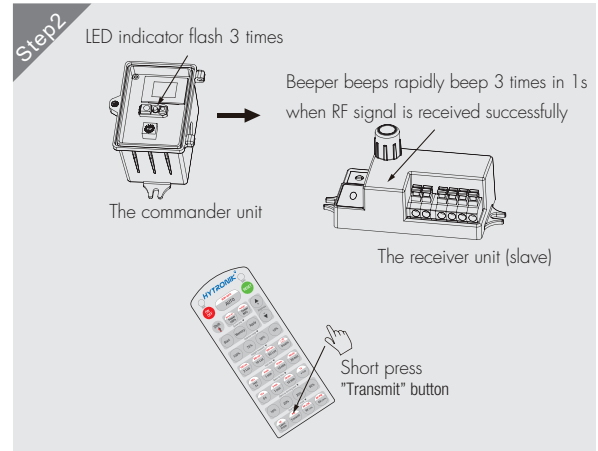

Erase:

Long press "Learn/Erase" button for 3s to the sensor unit. The beeper beeps rapidly for about 5s. All commands received before are erased.

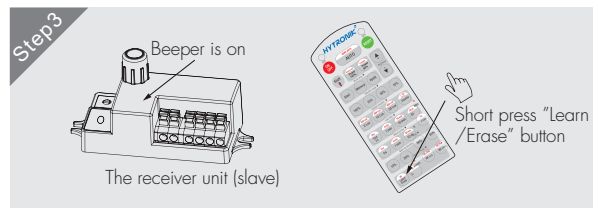

Detection Pattern

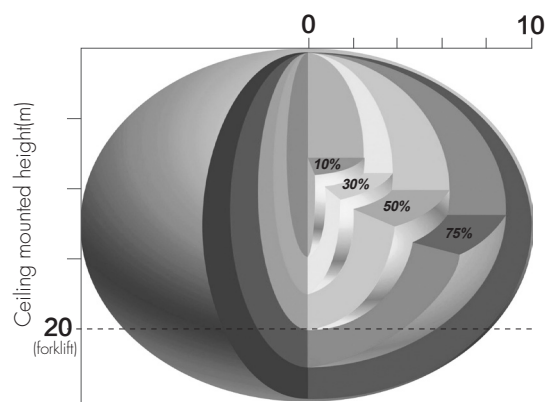

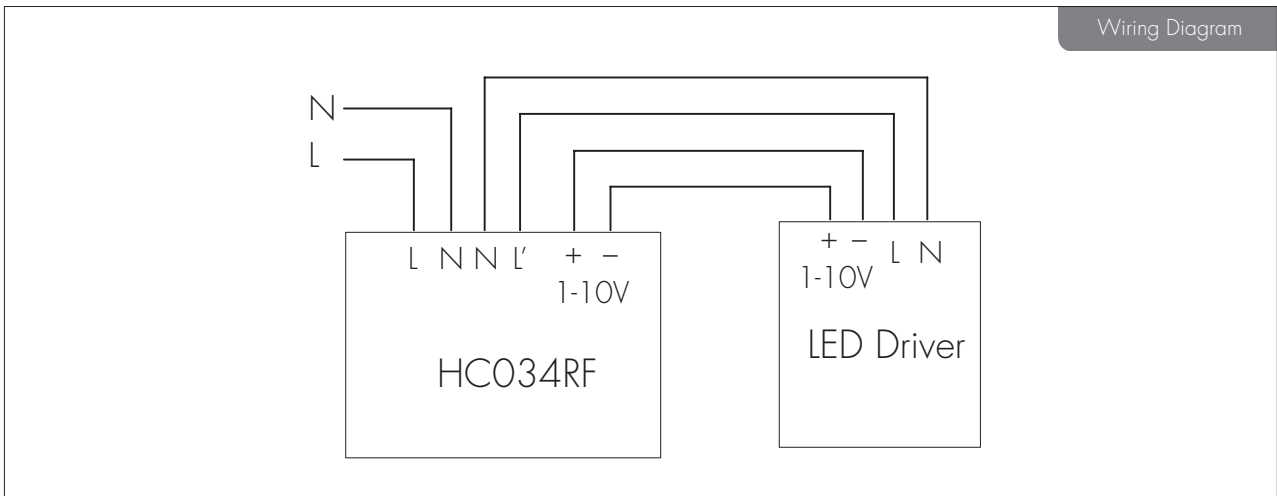
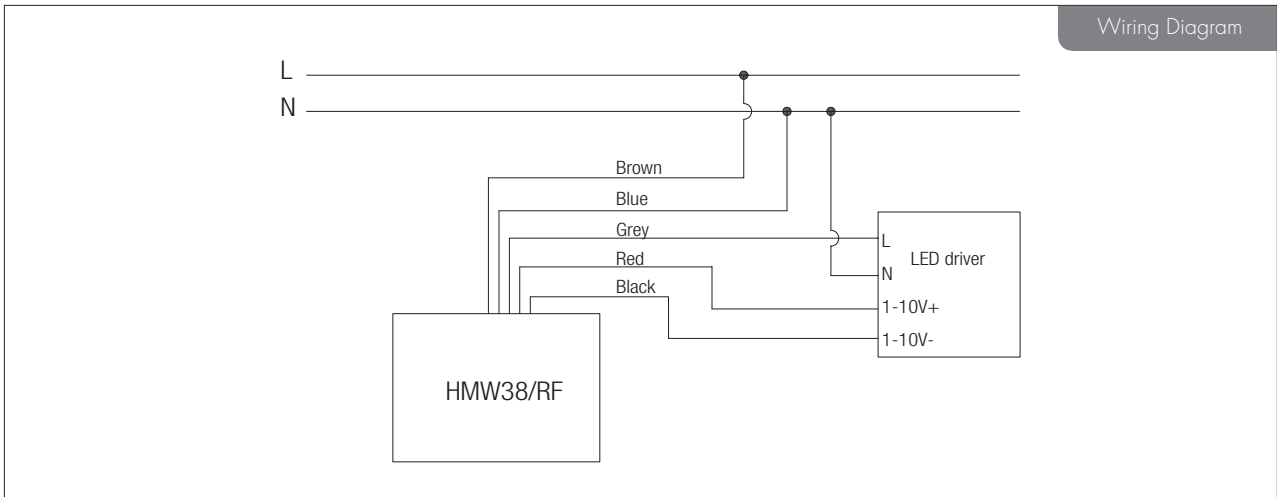

Additional Information / Documents

1. Regarding precautions for microwave sensor installation and operation, please kindly refer to www.hytronik.com/download ->knowledge ->Microwave Sensors - Precautions for Product Installation and Operation
2. Regarding precautions for RF sensor installation and operation, please kindly refer to www.hytronik.com/download ->knowledge ->RF Sensors - Precautions for Product Installation and Operation
3. Regarding Hytronik standard guarantee policy, please refer to www.hytronik.com/download ->knowledge ->Hytronik Standard Guarantee Policy

IP65 High Bay HF Motion Sensor

HYTRONIK®

HMW39/RF
DALI Dimming with RF Wireless Transmission

Technical Data

Input Characteristics

Model No.	HMW39/RF
Mains voltage	220~240VAC 50/60Hz
Stand-by power	<1.5W
Rated load	Maximum 40mA
Load ratings:	
HC034RF (IP20)	400VA (capacitive); 1200W (resistive)
Warming-up	20s

Safety and EMC

EMC standard (EMC)	EN55015, EN61000
Safety standard (LVD)	EN60669-1, EN60669-2-1
Radio Equipment (RED)	EN300440, EN301489-1, EN62479
Certification	Semko, CB, CE, EMC, RED, RCM

Sensor & RF Data

Model No.	HMW39/RF
Sensor principle	High Frequency (microwave)
Operation frequency	5.8GHz +/- 75MHz
Transmission power	<0.2mW
Detection range	Installation Height : 20m (forklift) 15m (person) Detection Range (Ø) : 20m
Detection angle	360°
RF frequency	868MHz (FSK mode)
RF transmission distance	30m indoor, 50m outdoor

Environment

Operation temperature	Ta: -20°C ~ +50°C
IP rating	IP65







CB IP65

Mechanical Structures and Installations

For more details, please refer to user manual.

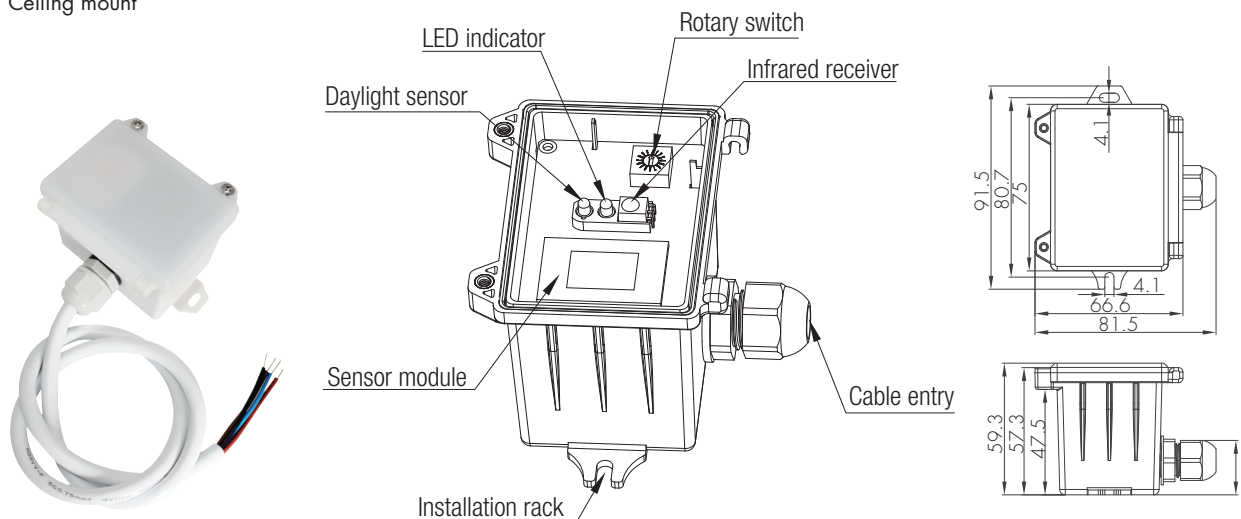
A. Ceiling mount



B. Screw to the Luminaire by conduit

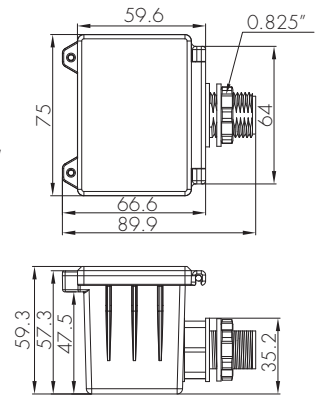
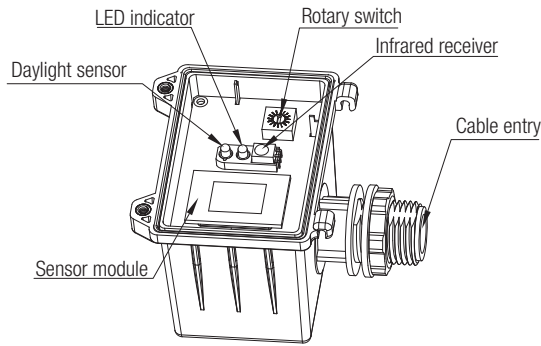

C. Attach to the shade by clamp

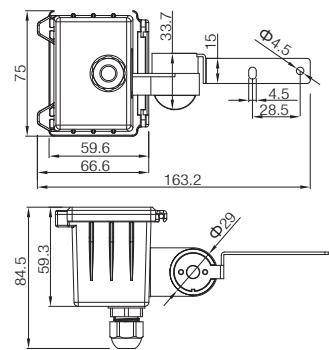
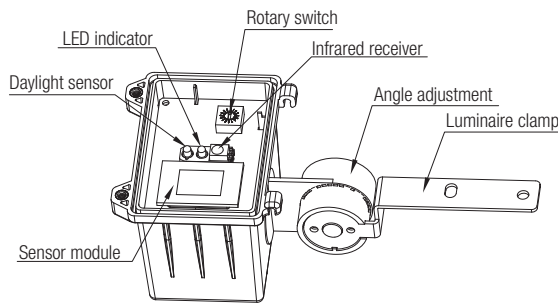

The motion detected by the master unit HMW39/RF passes to all other units programmed on the same group via RF transmission. The transmission can reach 30 meters indoor and 50 meters in open areas. A daylight sensor is also built-in to prevent the light switching on when surrounding natural light is sufficient.

Note: We recommend the mounting distance between sensor to sensor should be more than 4m to prevent sensors from false-triggering.

RF receiver serves as slave only, which turns on the light after receiving the RF "ON" signal from the master.

HC034RF (1-10V output, RF grouping by rotary switch or remote control)

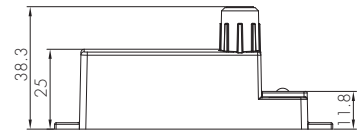
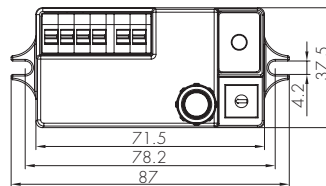
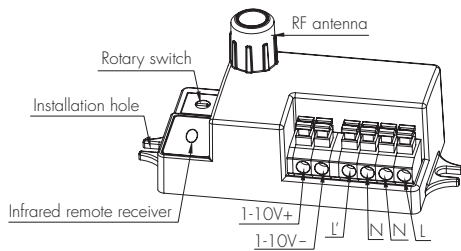

Distance Recommended between Sensors

Pay attention: The RF signal could be affected by big metal plate & wireless devices such as GSM mobile antenna, strong Wifi signal, ultra high-voltage cable which emits frequent electromagnetic waves radiation, which may interfere with the RF transmission and communication! Please always check the application environment before mass installation!

We recommend the mounting distance between sensors to be more than 6m to avoid sensors from being false-triggered.

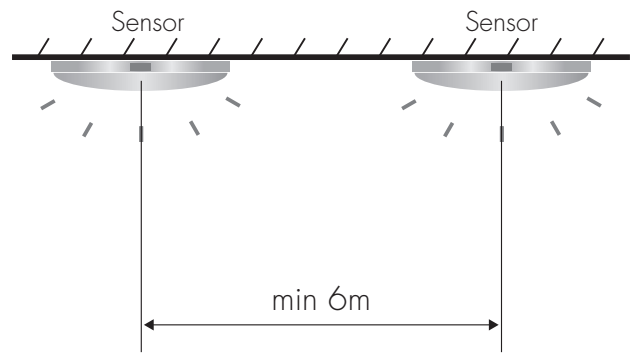

Functions and Features

1 Tri-level Control (Corridor Function)

Hytronik builds this function inside the motion sensor to achieve tri-level control, for some areas which require a light change notice before switch-off. The sensor offers 3 levels of light: 100%-->dimmed light (natural light is insufficient) -->off; and 2 periods of selectable waiting time: motion hold-time and stand-by period; Selectable daylight threshold and freedom of detection area.

2 Intelligent Photocell (daylight detection prior to motion detection)

The built-in photocell will also automatically turn off the light when the ambient natural light exceeds the programmed lux level for more than 5min, regardless of whether motion is detected or not. This feature can be disabled if it is required that the fixture stays at dimmed level during absence.



With sufficient natural light, the light does not switch on when presence is detected.

With insufficient natural light, the sensor switches on the light automatically when presence is detected.

The sensor switches off the light when natural light is sufficient, even with presence.

Note: if the stand-by time is preset at "+∞", the fixture never switches off but stays at preset dimming level even when natural light is sufficient.

RF Grouping by Rotary Switch (Maximum 15 channels)

15 channels are available for fast grouping via rotary switch on both HMW39/RF and the receiver HC034RF. Simply selecting the same channel on each unit, the grouping is automatically completed.

Noted: channel "0" is not for fast grouping, and sensors can only be grouped by remote control.

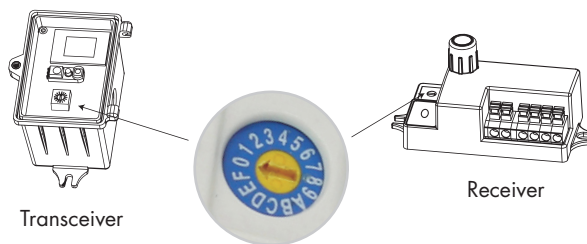

Typical Applications

1 For warehouse (HMW39/RF as both transmitter and receiver)

Settings on this demonstration:

Detection range: 100% Hold-time: 10min Daylight threshold: 100lux Stand-by dimming level: 30% Stand-by period: 10min RX: STBY%

Night

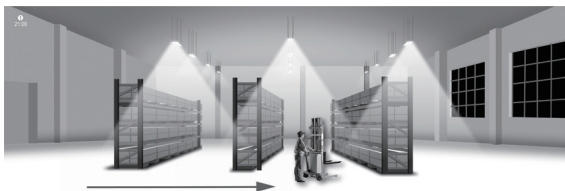

Daytime



Settings (Remote Control HRC-11)

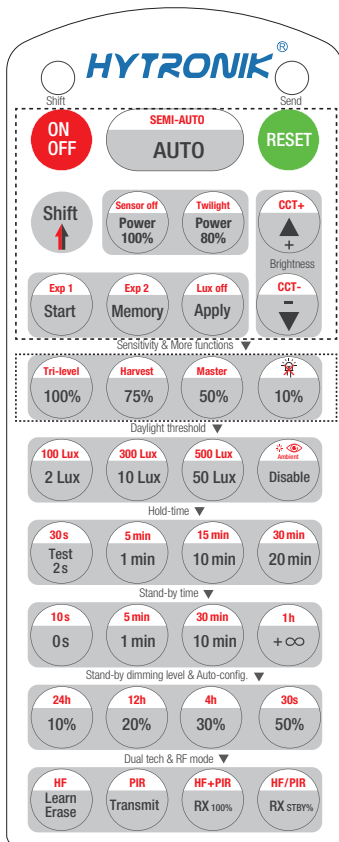

HRC-11

	Press button "ON/OFF" to select permanent ON or permanent OFF mode. * Press button "AUTO"/ "RESET" to exit this mode.
	Press button "RESET", perform DIP Switch/Rotary Switch settings. The default settings are: Auto mode; Detection range:100%; Hold time:1 min; Stand-by time:5min; Stand-by dimming level:20%; Daylight sensor disable; RX 100%.
	Press button "Shift", the LED on the top left corner is on to indicate mode selection. All values / settings in RED are valid for 20 seconds.
AUTO	Press button "AUTO" to initiate automatic mode. The sensor starts working and all settings remain as before the light is switched ON/OFF;
SEMI-AUTO	This key is not applicable on this product.
Power 100% 80%	Press buttons in zone "Power out" to select the light output at 80% (at initial 10,000 hours) or 100%.
Sensor off Twilight	This key is not applicable on this product.
	Press these two buttons to adjust the light output brightness and set a new target lux level. The daylight sensor can measure ambient daylight level and ignore the LED light, so as to calculate how much artificial light is needed to maintain the target lux level.
CCT+ CCT-	This key is not applicable on this product.
Start Memory Apply	<ol style="list-style-type: none"> 1. Press button "Start" to program. 2. Select the buttons in "Detection range", "Daylight threshold", "Hold-time", "Stand-by time", "Stand-by dimming level" to set all parameters. 3. Press button "Memory" to save all the settings programmed in the remote control. 4. Press button "Apply" to set the settings to each sensor unit(s). <p><i>For example, to set detection range 100%, daylight threshold Disable, hold-time 5min, stand-by time +∞, stand-by dimming level 30%, the steps should be: Press button "Start", button "100%", "Disable", "Shift", "5min", "Shift", "+∞", "30%", "Memory". By pointing to the sensor unit(s) and pressing "Apply", all settings are passed on the sensor(s).</i></p>
Lux off	This key is not applicable on this product.
Exp 1 Exp 2	"Exp" refer to Expansion, these two buttons are reserved functions and pending future development.
Sensitivity & More functions	
100% 75% 50% 10%	In AUTO modes, press buttons in zone "Detection range" to set detection range at 100%/75%/50%/10%.
Tri-level Harvest	This key is not applicable on this product.
Master	This key is not applicable on this product.

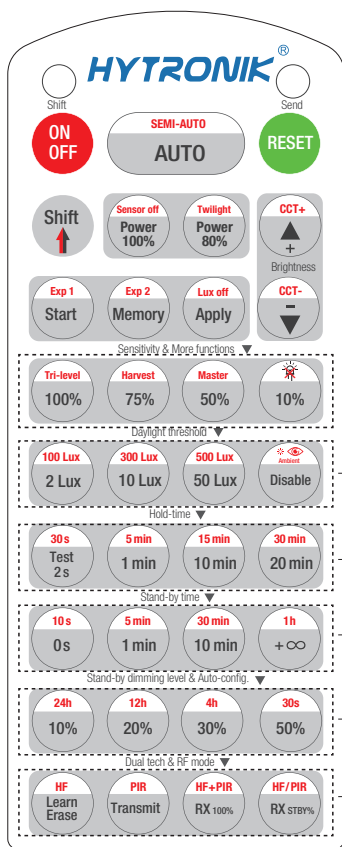

HRC-11

Daylight threshold	
2 Lux 100 Lux 10 Lux 300 Lux 50 Lux 500 Lux Disable	Press buttons in zone "Daylight threshold" to set daylight sensor at 2Lux/ 10Lux / 50Lux / 100Lux / 300Lux/500Lux / Disable. <i>Note: To set daylight sensor at 100Lux / 300Lux/500Lux , press "Shift" button first.</i>
	1. Press button "Shift", the red LED on. 2. Press button "Ambient", the surrounding lux level is sampled and set as daylight threshold / target Lux level.
Hold-time mode	
Test 2s 30s 1 min 5 min 10 min 15 min 20 min 30 min	In AUTO modes, press buttons in zone "hold-time" to set the hold-time at 2s / 30s / 1min / 5min / 10min / 15min / 20min / 30min. <i>Note: 1. To set hold-time at 30s / 5min / 15min / 30min, press "Shift" button first. 2. 2s is for testing purpose only, stand-by period and daylight sensor settings are disabled in this mode.</i> *To exit from Test mode, press button "RESET" or any button in "Hold-time".
Stand-by time mode	
0s 10s 1 min 5 min 10 min 30 min +∞ 1h	Press buttons in zone "stand-by time" to set the stand-by period at 0s / 10s / 1min / 5min / 10min / 30min / 1h / +∞. <i>Note: 1. To set stand-by-time at 10s/ 5min / 30min / 1h, press "Shift" button first. 2. "0s" means on/off control; 3. "+∞" means bi-level control, the fixture is 100% on when there is motion detected, and remains at the stand-by dimming level when no presence after motion hold-time. Only when the stand-by time is set in "+∞" and the ambient lux level is below the target lux level, the lux will auto-on.</i>
Stand-by dimming level & Auto-config.	
10% 20% 30% 50%	Press the button in zone "stand-by dimming level" to set the stand-by dimming level at 10% / 20% / 30% / 50%.
24h 12h 4h 30s	This key is not applicable on this product.
Dual tech & RF mode	
Learn Erase Transmit	Short press "learn/erase" button to activate pairing mode, then press "transmit" on a primary mode and all the receiver modules will beep 3 times in 1s to indicate the success of paring. Long press the "learn/erase" button for 3s will erase all the commands received previously.
RX 100% RX STBY%	Press button RX100%, the light on receiver unit is 100% upon receiving RF on signal; Press button "RX STBY%", the light(s) oes to pre-set stand-by dimming level directly.
HF PIR HF+PIR HF/PIR	This key is not applicable on this product.

RF grouping by HRC-11

Short press "Learn/Erase" button on RC to activate pairing mode, and the receiver unit starts to beep once every second for 3min.

Note: up to 30 units can be paired.



Short press "Transmit" button on RC, the commander unit (master unit) beeps one time to send the transmission signal.

Upon receiving the transmission signal, the receiver unit (slave unit) rapidly beeps 3 times in 1s to indicate the success of pairing. Repeat this step to pair more units.

One more short press on "Learn/Erase" button to the receiver unit to complete the pairing process, the receiver unit will quit the pairing mode.

Note: Press button RX100%, the light on receiver unit is 100% on upon receiving RF on signal; Press "RX STBY%" button, the light(s) goes to preset stand-by dimming level directly.

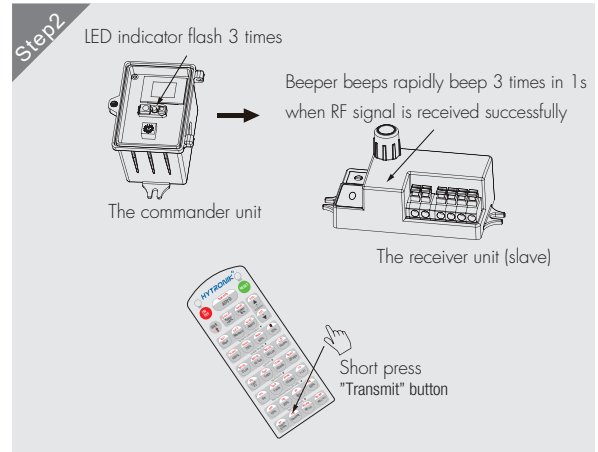

Erase:

Long press "Learn/Erase" button for 3s to the sensor unit. The beeper beeps rapidly for about 5s. All commands received before are erased.

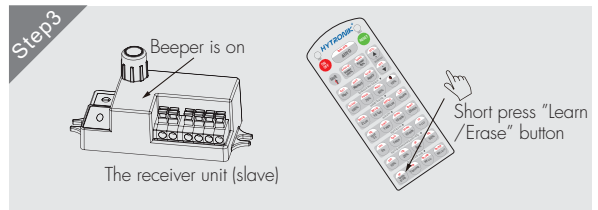

Detection Pattern

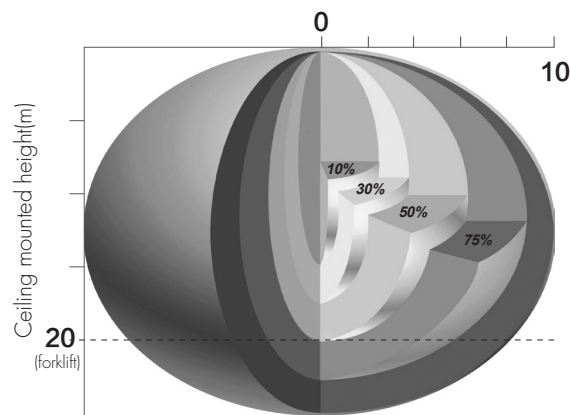

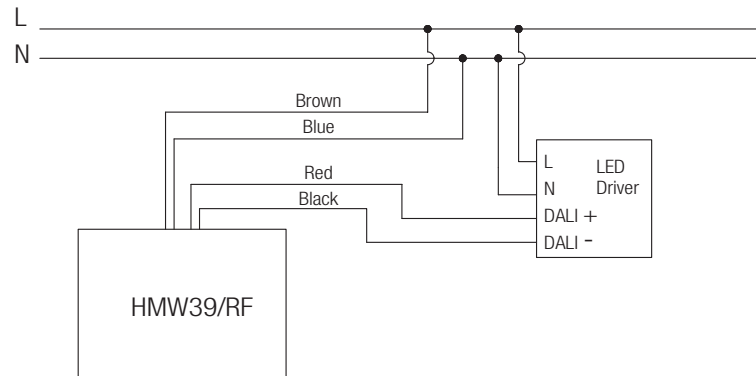

— This product should be installed by a qualified electrician.

1. 200 metres (total) max. for 1mm² CSA (Ta = 50°C)
2. 300 metres (total) max. for 1.5mm² CSA (Ta = 50°C)

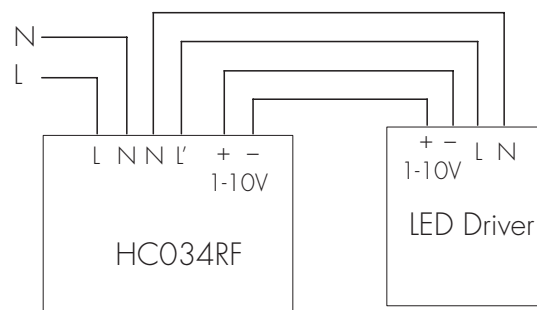

Additional Information / Documents

1. Regarding precautions for microwave sensor installation and operation, please kindly refer to [www.hytronik.com/download ->knowledge ->Microwave Sensors - Precautions for Product Installation and Operation](http://www.hytronik.com/download->knowledge->Microwave%20Sensors%20-%20Precautions%20for%20Product%20Installation%20and%20Operation)
2. Regarding precautions for RF sensor installation and operation, please kindly refer to [www.hytronik.com/download ->knowledge ->RF Sensors - Precautions for Product Installation and Operation](http://www.hytronik.com/download->knowledge->RF%20Sensors%20-%20Precautions%20for%20Product%20Installation%20and%20Operation)
3. Regarding Hytronik standard guarantee policy, please refer to [www.hytronik.com/download ->knowledge ->Hytronik Standard Guarantee Policy](http://www.hytronik.com/download->knowledge->Hytronik%20Standard%20Guarantee%20Policy)