

# Microwave Sensors – Precautions for Product Installation and Operation



Preamble:

Thank you for choosing Hytronik. We are committed to providing microwave motion sensor products of the highest quality and offering clear guidance for safe and reliable installation and operation.

To ensure optimal performance, maintain product reliability, and provide a smooth user experience, the following installation and operation precautions apply to all Hytronik microwave sensor devices.

## 1. Operating Principle

Microwave motion sensors detect occupancy by using High Frequency (HF) signals. This technology is based on the Doppler effect, which allows the sensor to determine the size, speed, and movement direction of an object. In simple terms, it functions like a radar — the antenna emits signals and analyzes the reflected waves.

## 2. Installation Considerations

To ensure stable performance, always perform field tests before mass installation, as microwave sensors are easily affected by environmental conditions.

- Factors that may affect sensor performance
  1. Wireless interference: strong Wi-Fi signals, GSM towers, etc.
  2. Metal materials: iron, steel, reinforced concrete, etc.
  3. Moving objects: ventilation fans, water pipes, air movement, elevators, small animals, etc.
  4. Vibration: from air traffic, surrounding machinery, or suspended mounting conditions.
  5. Back wave reflection: Signal reflection from the wall surface.
  6. Confined spaces: HF signals can penetrate wood or gypsum partitions in small compartments such as toilet cubicles.
  7. Outdoor environments: wind, rain, or moving vegetation can easily cause false triggers.
- Mounting distance

Avoid installing two luminaires with microwave sensors too close to each other, as they may detect each other's signals and cause false triggering. Keep at least 3 meters distance between sensors. Similarly, avoid mounting sensors face-to-face on opposite walls, as they may detect each other's emissions.

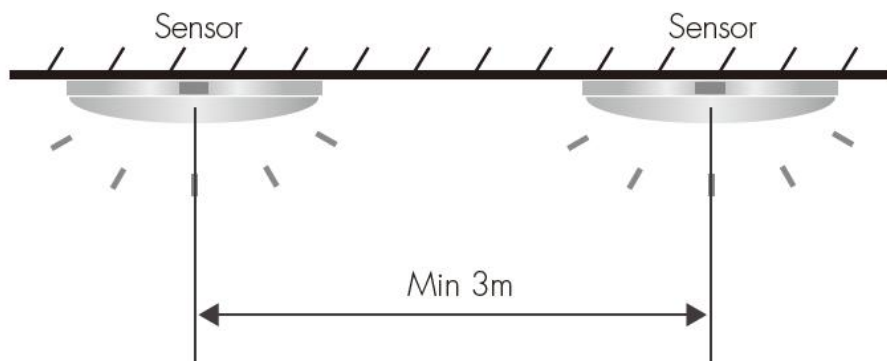

### 3. Detection Range Variations

The actual detection distance of a microwave sensor may vary depending on several conditions:

- Testing Methods: Continuous Walking vs. Walk-and-Stop
1. Detection Distance: The detection distance achieved using the walk-and-stop method is longer than that of continuous walking.
  2. Explanation: When a person walks continuously at a constant speed towards the sensor, the microwave detection mechanism may interpret the steady movement as having minimal frequency variation, resulting in a slower sensor response.
  3. Comparison: In contrast, the walk-and-stop movement creates more distinct changes, allowing the microwave sensor to respond more promptly. This typically increases the detection range by 1 to 3 meters.
  4. Important Note: Please be advised that all detection ranges specified in our microwave sensor datasheets are determined using the walk-and-stop test method.

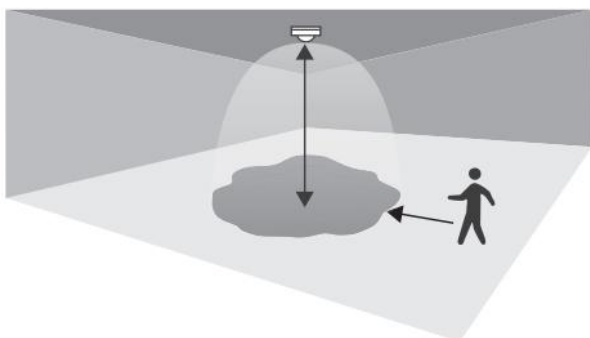

Walking continuously

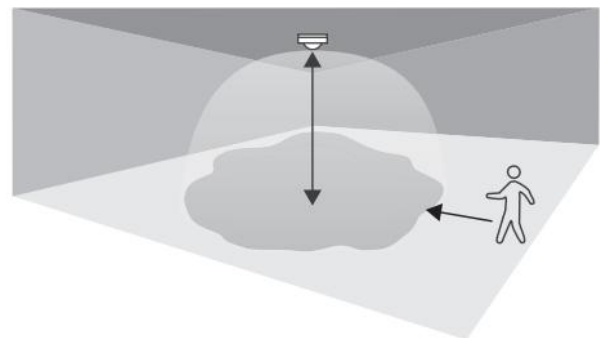

Walk-and-stop

- Human Size and Speed

Detection distance data is based on a 170cm-tall tester walking at 0.5 – 1.0 m/s.

- Testing Field

To ensure accurate and repeatable results, testing should be conducted in a spacious indoor area with ceiling, similar to real applications.

- Walking Direction & Mounting Position

The detection distance of a microwave sensor varies depending on both the walking direction and the sensor's mounting position.



1. Ceiling-mounted sensors: When a person walks across the detection area beneath the sensor (tangential movement), the sensor responds faster and the detection distance is generally longer.
2. Wall-mounted sensors: When a person walks directly towards the sensor (radial movement), the sensor responds more slowly and the detection distance is typically shorter.

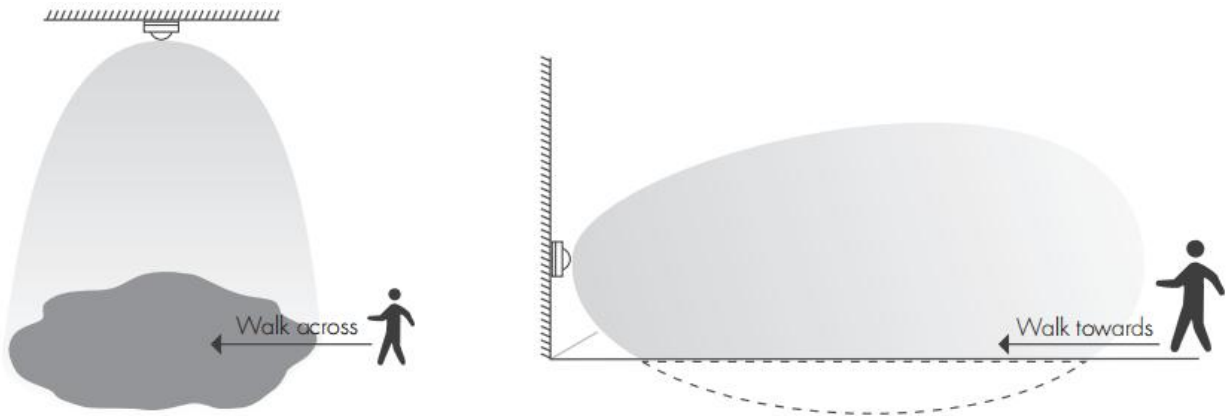

- Detection Pattern

The detection pattern of a microwave sensor is not a perfect circle. One direction may have a relatively shorter detection radius (e.g., Direction 4 in the illustration), which is inherent to the nature and characteristics of the microwave module. The maximum detection range shown on the datasheet refers to the most sensitive directions (e.g., Direction 1 & 2 in the illustration).



- Luminaire & Ceiling Material

HF signals can be reflected or attenuated by luminaire parts or ceiling materials. For example, metal components reflect the signal, while materials like thick polycarbonate can attenuate it, reducing the effective range.



- Sensor Installation

When fitting the sensor body in a luminaire, please also kindly pay attention that when a motion sensor is installed at or well below the LED gear tray level, the detection range can be affected. It is always highly recommended to expose the antenna part:



- LED Driver Soft-On Delay

When the sensor is triggered to switch on the lights, certain LED driver models may require a longer response time. As a result, the lights may turn on with a slight delay, which could be mistakenly interpreted as a sensor sensitivity issue or a shorter detection distance.

△ Please note that in real applications, such factors can cause slight variations in detection range. Therefore, a universal standard cannot be defined for all situations. To verify the actual detection pattern for a specific installation, it is recommended to perform a small field test before mass installation.

#### 4. Ta and Tc

- Definition

1. Ta refers to the maximum ambient temperature — specifically, the air surrounding the motion sensor inside the luminaire.
2. Tc refers to the maximum temperature at a reference point on the sensor housing.

- Key Notes

1. The Tc reference point is defined by Hytronik. Manufacturers may define this point differently, as there is no unified standard.
2. As long as the Ta and Tc temperatures measured on the sensor housing remain within the maximum predefined values stated in the datasheet, a 5-year lifetime is guaranteed.



3. However, if these temperatures exceed the limits, the sensor's lifetime will be shortened (though it will still function). In such cases, the Hytronik standard warranty does not apply, as the product is not used according to the specifications.

## 5. Operation Under Extremely Low Temperature

The rated minimum working temperature of Hytronik microwave motion sensor is generally  $-20^{\circ}\text{C}$  (For exact value, please kindly refer to the specific product data sheet). However, in special application, the microwave motion sensor is intended to work in an environment with temperature lower than  $-20^{\circ}\text{C}$ , such as in a cold storage. In this case, there are a few aspects which require special attention:

- To enable the sensor working in such environment, some users may start up the microwave sensor under normal temperature level first, i.e. more than  $-20^{\circ}\text{C}$ . After starting up, the user will need to keep the sensor working under this normal temperature range for at least 30 minutes to fully warm up the sensor internal parts. After warm-up, user can further decrease the operation temperature to a lower level. However, please kindly take note that the lowest temperature level it can go is  $-40^{\circ}\text{C}$ .
- In case of power outage, the user has to repower on the sensor under normal temperature level again. Before further decreasing the operation temperature of the cold storage to below  $-20^{\circ}\text{C}$ , the sensor has to keep working under normal temperature for at least 30 minutes to totally heat up the sensor internal parts again.

△ For such special application, the lifetime of the sensor will be reduced. Hytronik standard guarantee is not applicable as the product is not used according to the specifications.

## 6. Remote Control Commissioning

Some PIR sensors require commissioning via remote control.

- Battery  
Use two AAA batteries. Replace when the LED indicator or sensor becomes unresponsive.
- Operating Distance and Angle  
When commissioning, point the remote control within  $\pm 15^{\circ}$  vertical angle toward the sensor.  
For high-bay sensors (10–15m installation height), LED flashing from both remote and controlled lights indicates successful transmission.



- Infrared Interference

Signal transmission may fail in environments with strong infrared light, such as fluorescent lamps, incandescent lamps, or direct sunlight.

## 7. Inrush Current

When an LED driver powers on, an instant inrush current up to 50 times the steady-state current can occur.

Ensure the total inrush current from connected LED drivers is below the sensor's rated limit to prevent damage.

- Parallel Connection and Load Limitation

When multiple PIR sensors are connected in parallel via the L' terminal for group synchronization, the following points must be observed:

1. The inrush current from each LED driver must not exceed the limit that the sensor can withstand.
2. The total load of all sensors connected in parallel must not exceed the rated load of a single sensor.

Example:

For instance, if a single HIR28 PIR sensor has a rated capacitive load of 400VA, it can be connected with 13 pieces of 30W luminaires in parallel:  $30W \times 13 = 390VA < 400VA$ .

- Lifetime Impact

If the inrush current from the LED driver exceeds the sensor's rated limit, the sensor may still operate, but its lifetime will be shortened. In such cases, the Hytronik standard warranty does not apply, as the product is not used according to the specified conditions.



## HYTRONIK INTERNATIONAL

### **Hytronik UK:**

Unit 3 Tallow Way, Fairhills Industrial Estate, Irlam, Manchester, M44 6RJ, United Kingdom

E-mail: [info@hytronik.com](mailto:info@hytronik.com)

### **Hytronik DACH:**

Heinrich-Hertz-Straße 15 / 65582 Diez. Germany

E-mail: [support\\_dach@hytronik.com](mailto:support_dach@hytronik.com)

### **Hytronik Iberia & Latam:**

Carrer del Moro Zeid, 11, Piso 3, Ciutat Vella, 46001 Valencia

E-mail: [support\\_dach@hytronik.com](mailto:support_dach@hytronik.com)

### **Hytronik SVK & CZE:**

Techlum s.r.o (Slovakia, Slovenia) Staré Grunty 7A 841 04 Bratislava

E-mail: [info@techlum.sk](mailto:info@techlum.sk)

### **Hytronik Asia:**

Pude Industrial Park, Dushi Village, Pingtan Town, Huiyang District, Huizhou City 516259

E-mail: [info@hytronik.com](mailto:info@hytronik.com)

