

## HIM34

HF and PIR, Daylight Harvest for Independent DALI

### Technical Data

#### Input Characteristics

Model No.	HIM34
Mains voltage	220~240VAC 50/60Hz
Stand-by power	<1W
Switched power	Max. 20pcs devices, 40mA
Warming-up	30s

#### Safety and EMC

EMC standard (EMC)	EN55015, EN61000-3-2/-3-3
Safety standard (LVD)	EN60669-1/-2-1, AS/NZS60669-1/-2-1
Radio Equipment (RED)	EN300440, EN301489-1-3, EN62479
Certification	CE, UKCA

#### Sensor Data

Model No.	HIM34
Sensor principle	High Frequency (microwave), PIR
Operation frequency	5.8GHz +/- 75MHz (HF)
Transmission power	<0.2mW (HF)
Sensor mode	PIR, HF, PIR+HF, PIR/HF
Detection area (Max.)*	Max installation height: 1.5m (forklift)/1.2m (human) Max detection range: HF: Ø = 24m (forklift)/14m (human) PIR: Ø = 24m (forklift)/20m (human)
Detection range	10% / 50% / 75% / 100%
Detection angle	360°

#### Environment

Operation temperature	Ta: -20°C ~ +50°C
IP rating	IP65



### Mechanical Structures and Installations

For more details, please refer to user manual.

#### A. Ceiling mount (HIM34A)

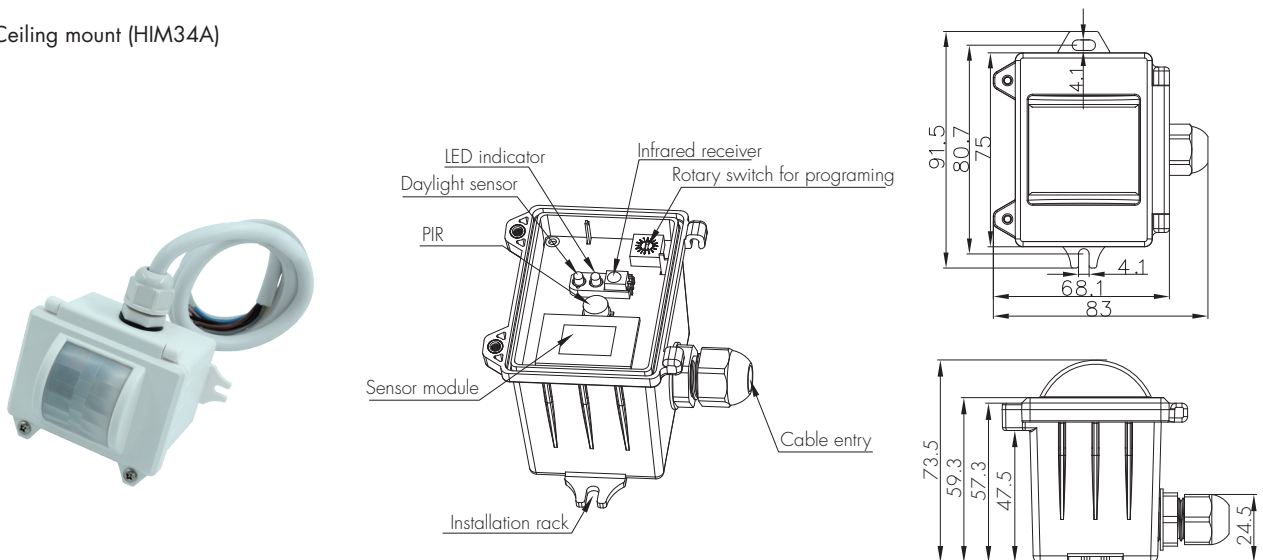

**B. Screw to the Luminaire by conduit (HIM34B)**

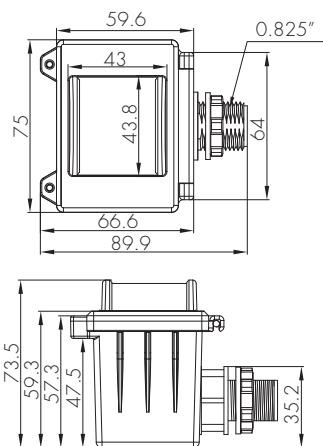
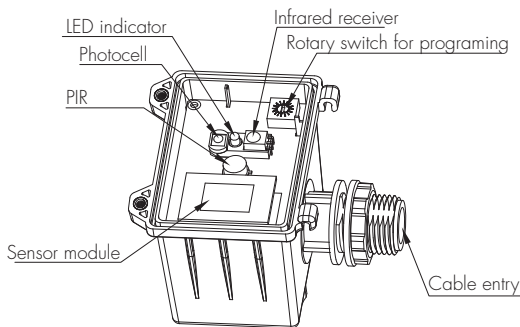

**C. Attach to the shade by clamp (HIM34C)**

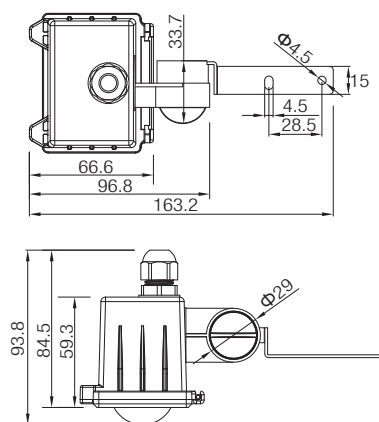
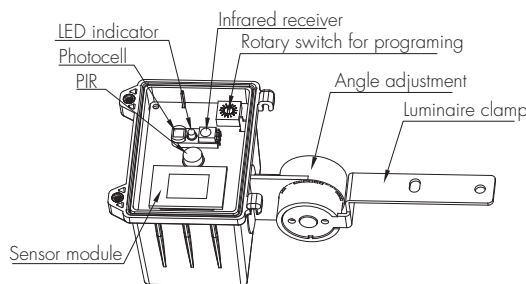

**Dual Sense Introduction**

It's commonly known Microwave and Infrared are main detecting technologies in lighting controls. Both have the advantage and disadvantage for industrial applications.

**Advantage**

- \* sensitive to minor motion.
- \* sensitive to radial movement.
- \* can be reflected by objects hence covering big detection area
- \* resilient to heat source, smoke and air conditioner.



**Advantage**

- \* no penetration, confined detection area.
- \* sensitive to tangential movement.
- \* resilient to motion object which has no heat radiation.



**Disadvantage**

- \* penetrates walls, picks up motions outside of the office area;
- \* back wave detection, false trigger by motions at the back.
- \* can be false triggered by ventilation fans, water pipe, elevators etc. in industrial application.

**Disadvantage**

- \* can be false triggered by air conditioner, smoke and other heat sources.

The remedy is to create Dual Sense by combining both technologies to make use of the advantage and bypass the disadvantage.

**4 optional detection modes via remote control:**

- \* HF: Microwave only
- \* PIR: PIR mode only
- \* HF+PIR: both PIR and microwave mode, to decrease the detection capability and detection area. Only when both detections are activated, the motion is considered valid. This is to prevent the sensor from false trigger by heat source, air conditioner, ventilation fans, water pipe and elevators etc...
- \* HF/PIR: either PIR or microwave mode, to increase the detection capability and detection area;

## Wiring Diagram

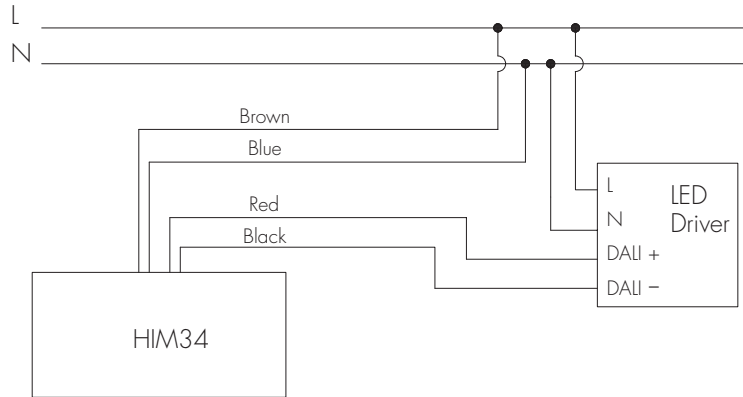

1. 200 metres (total) max. for 1mm<sup>2</sup> CSA (Ta = 50°C)
2. 300 metres (total) max. for 1.5mm<sup>2</sup> CSA (Ta = 50°C)

## Detection Pattern

End user can choose the suitable PIR lens in real application to fulfill various requirements. Three options are offered for selection: (only 1 lens is in the package, selected lens type should be specified on purchase order!)

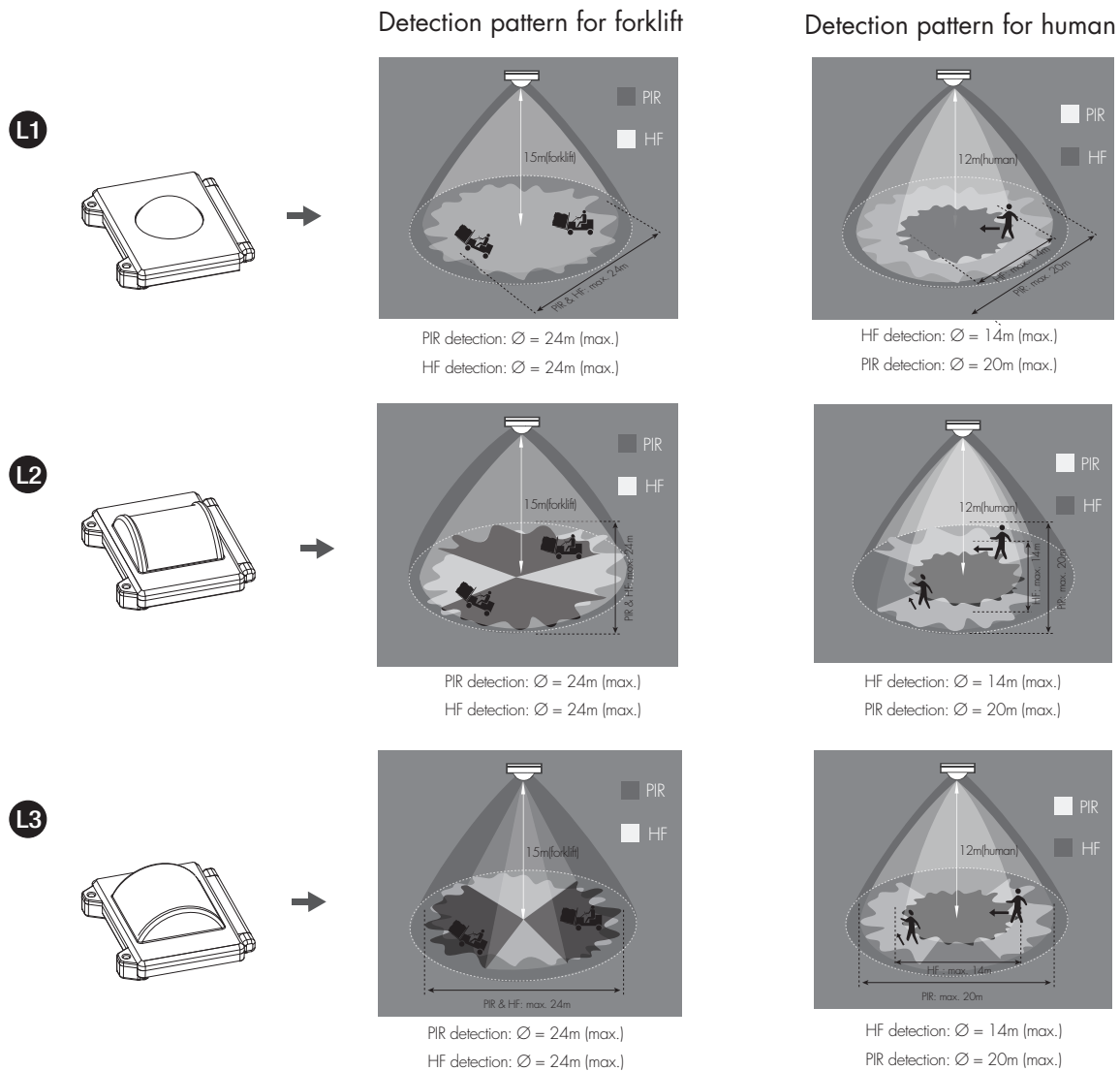

## Functions and Features

### 1 Daylight Harvest



Light will not switch on when natural light is sufficient, even there is motion detected.

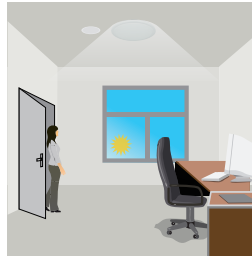

The light switches on automatically with presence when natural light is insufficient.

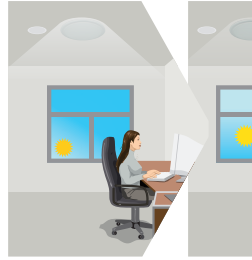

The light turns on at full or dims to maintain the lux level. The light output regulates according to the level of natural light available.



The light switches off when the ambient natural light is sufficient.

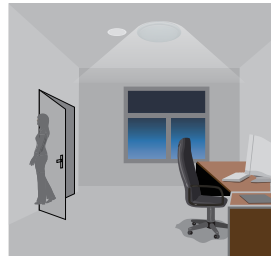

The light dims to stand-by period after hold-time and stays on selected minimum dimming level.



The light switches off completely after the stand-by period.

**Note:**

The light automatically dims down and eventually turns off if the natural light lux level exceeds the daylight threshold. However, if the stand-by period is preset at "+∞", the fixture never switches off but dim to minimum level, even the natural light is sufficient.

### Rotary Switch Preset

A rotary switch is built inside the sensor for scene selection / fast programming. Total 16 channels are available:



Rotary switch preset (Please see the location in 4. Installation)

Channel	Detection range	Hold-time	Daylight sensor	Stand-by time	Stand-by dim level
0	100%	5s	10s	10%	Disable
1	100%	1min	5min	10%	50Lux
2	100%	5min	10min	10%	50Lux
3	100%	5min	+∞	10%	75Lux
4	100%	5min	+∞	10%	100Lux
5	100%	5min	+∞	30%	200Lux
6	100%	10min	30min	10%	50Lux
7	100%	10min	+∞	10%	75Lux
8	100%	10min	+∞	10%	100Lux
9	100%	10min	+∞	30%	200Lux
A	100%	20min	1h	10%	100Lux
B	100%	20min	+∞	30%	200Lux
C	100%	30min	+∞	10%	100Lux
D	100%	30min	+∞	30%	200Lux
E	100%	30min	+∞	50%	400Lux
F	100%	5s	10s	10%	100Lux

Note: settings can also be changed by remote control HRC-11. The last action controls.

## Settings (Remote Control HRC-11)

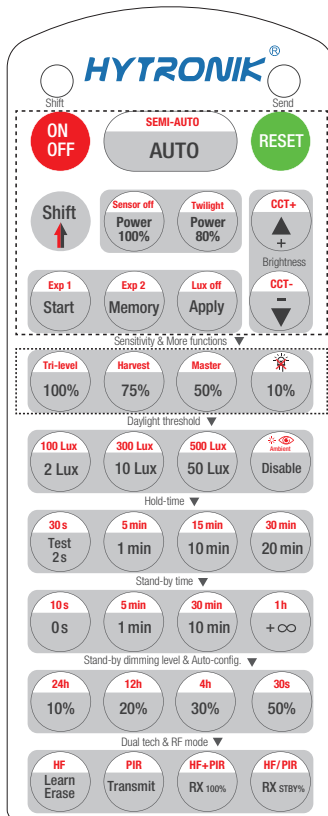

HRC-11

	Press button "ON/OFF" to select permanent ON or permanent OFF mode. * Press button "AUTO"/ "RESET" to exit this mode.
	Press button "RESET", perform DIP Switch/Rotary Switch settings.  *The default settings are: Detection range 100%; Hold-time 5min; Stand-by time +∞; Stand-by dimming level 10%; Daylight threshold 100 Lux; HF/PIR detection mode.
	Press button "Shift", the LED on the top left corner is on to indicate mode selection. All values / settings in RED are valid for 20 seconds.
<b>AUTO</b>	Press button "AUTO" to initiate automatic mode. The sensor starts working and all settings remain as before the light is switched ON/OFF;
<b>SEMI-AUTO</b>	This key is not applicable on this product.
<b>Power 100% 80%</b>	Press buttons in zone "Power out" to select the light output at 80% (at initial 10,000 hours) or 100%.
<b>Sensor off</b>	1. Press button "Shift", the red LED on. 2. Press button "Sensor off", the function of movement detection is disabled, the function of photocell is also disabled.
<b>Twilight</b>	To exit from "Sensor off" mode, press button "AUTO"/"SEMI-AUTO"/"RESET".  <i>Note: "Twilight" function is not applicable on this product.</i>
	Press these two buttons to adjust the light output brightness and set a new target lux level. The daylight sensor can measure ambient daylight level and ignore the LED light, so as to calculate how much artificial light is needed to maintain the target lux level.
<b>CCT+ CCT-</b>	This key is not applicable on this product.
<b>Start Memory Apply</b>	1. Press button "Start" to program. 2. Select the buttons in "Detection range", "Daylight threshold", "Hold-time", "Stand-by time", "Stand-by dimming level" to set all parameters. 3. Press button "Memory" to save all the settings programmed in the remote control. 4. Press button "Apply" to set the settings to each sensor unit(s).  <i>For example, to set detection range 100%, daylight threshold Disable, hold-time 5min, stand-by time +∞, stand-by dimming level 30%, the steps should be: Press button "Start", button "100%", "Disable", "Shift", "5min", "Shift", "+∞", "30%", "Memory". By pointing to the sensor unit(s) and pressing "Apply", all settings are passed on the sensor(s).</i>
<b>Lux off</b>	This key is not applicable on this product.
<b>Exp 1 Exp 2</b>	"Exp" refer to Expansion, these two buttons are reserved functions and pending future development.
Sensitivity & More functions	
<b>100% 75% 50% 10%</b>	In AUTO /SEMI-AUTO modes, press buttons in zone "Detection range" to set detection range at 100%/75%/50%/10%.
<b>Tri-level Harvest</b>	1. Press button "Shift", the red LED on. 2. Press buttons "Daylight harvest" to shift Daylight harvest mode.
<b>Master</b>	This key is not applicable on this product.

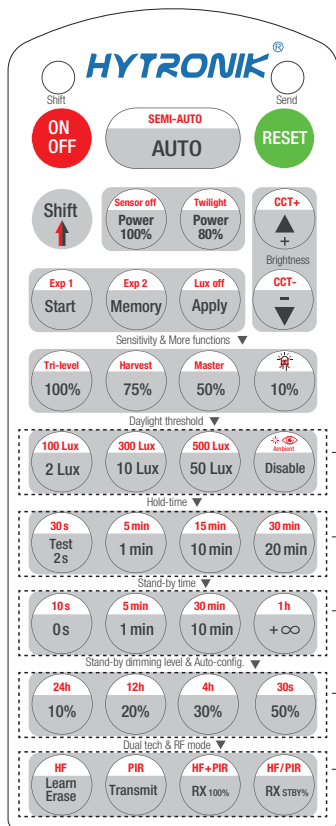

HRC-11

Daylight threshold	
2 Lux 100 Lux 10 Lux 300 Lux 50 Lux 500 Lux Disable	Press buttons in zone "Daylight threshold" to set daylight sensor at 2Lux / 10Lux / 50Lux / 100Lux / 300Lux/500Lux / Disable.  <i>Note: To set daylight sensor at 100Lux / 300Lux/500Lux , press "Shift" button first.</i>
	1. Press button "Shift", the red LED on. 2. Press button "Ambient", the surrounding lux level is sampled and set as daylight threshold / target Lux level.
Hold-time mode	
Test 2s 30s 1 min 5min 10 min 15min 20min 30min	In AUTO /SEMI-AUTO modes, press buttons in zone "hold-time" to set the hold-time at 2s / 30s / 1min / 5min / 10min / 15min / 20min / 30min.  <i>Note: 1. To set hold-time at 30s / 5min / 15min / 30min, press "Shift" button first. 2. 2s is for testing purpose only, stand-by period and daylight sensor settings are disabled in this mode.</i>  *To exit from Test mode, press button "RESET" or any button in "Hold-time".
Stand-by time mode	
0s 10s 1 min 5min 10 min 30min +∞ 1h	Press buttons in zone "stand-by time" to set the stand-by period at 0s / 10s / 1min / 5min / 10min / 30min / 1h / +∞.  <i>Note: 1. To set stand-by-time at 10s/ 5min / 30min / 1h, press "Shift" button first. 2. "0s" means on/off control; 3. "+∞" means bi-level control, the fixture is 100% on when there is motion detected, and remains at the stand-by dimming level when no presence after motion hold-time. Only when the stand-by time is set in "+∞" and the ambient lux level is below the target lux level, the lux will auto-on.</i>
Stand-by dimming level & Auto-config.	
10% 20% 30% 50%	Press the button in zone "stand-by dimming level" to set the stand-by dimming level at 10% / 20% / 30% / 50%.
24h 12h 4h 30s	1.Press button "Shift" ,the red LED on. 2.Select a time period and the sensor will do light level measurement and determine/save the lowest light level (commission line) with 100% light on, so as to set the target lux level automatically.  <i>Note:1.Make sure the light level measurement covers the night time. 2.The fixture will go into sensor mode after the measurement, all sensor setting remain unchanged.</i>
Dual tech & RF mode	
Learn Erase	This key is not applicable on this product.
Transmit	This key is not applicable on this product.
HF PIR HF+PIR HF/PIR	1.Press button "Shift" ,the red LED on. 2. Choose one of the four detection mode "HF only", "PIR only", "HF& PIR" or" HF/PIR".

## Additional Information / Documents

- Regarding precautions for microwave sensor installation and operation, please kindly refer to [www.hytronik.com/download ->knowledge ->Microwave Sensors - Precautions for Product Installation and Operation](http://www.hytronik.com/download->knowledge->Microwave Sensors - Precautions for Product Installation and Operation)
- Regarding Hytronik standard guarantee policy, please refer to [www.hytronik.com/download ->knowledge ->Hytronik Standard Guarantee Policy](http://www.hytronik.com/download->knowledge->Hytronik Standard Guarantee Policy)