

IP65 PIR Motion Sensor with Bluetooth® 5.0 SIG Mesh

HC049V/BT (High-bay)
0/1-10V Bolt-on/Batten-fit PIR Sensor



Product Description

HC049V/BT is a Bluetooth 0/1-10V high-bay PIR motion sensor, with capability of up to 15m installation height. HC049V/BT has a daylight sensor built-in, and is specifically designed for mounting onto a batten style luminaire. It is also designed for professional lighting manufactures who would like to incorporate wireless control into their luminaires. HC049V/BT is suitable for any typical indoor applications such as office, classroom, car park, warehouse and other commercial/industrial areas. With Bluetooth wireless mesh networking, it makes communication much easier without any hardwiring, which eventually adds values to luminaires and saves costs for projects. Meanwhile, simple device setup and commissioning can be done via **Koolmesh™** app.

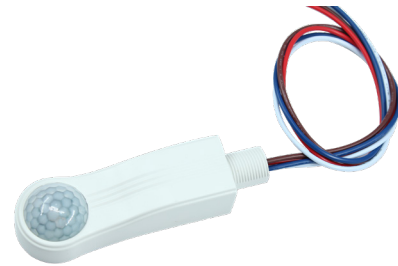

App Features

- Quick setup mode & advanced setup mode
- Web app/platform for project deployment & data analysis
- Koolmesh Pro app on iPad for on-site configuration
- Floorplan feature to simplify project planning
- One-key device replacement
- Device social relations check
- Staircase function (primary & secondary)
- Remote control via gateway support HBGW01
- Heat map
- Dynamic daylight harvest auto-adaptation
- Grouping luminaires via mesh network
- Scenes
- Dusk/Dawn photocell (Twilight function)
- Tri-level control
- Daylight harvest
- Detailed motion sensor settings
- Schedule
- Astro timer (sunrise and sunset)
- Power-on status (memory against power loss)
- Offline commissioning
- Bulk commissioning (copy and paste settings)
- Different permission levels via authority management
- Network sharing via QR code or keycode

- Compatible with EnOcean BLE switches
- Interoperability with Hytronik Bluetooth product portfolio
- Internet-of-Things (IoT) featured
- Device firmware update over-the-air (OTA)
- Continuous development in progress...

Hardware Features

- IP65
- Fixing washers accessory
- High-bay (up to 15m height)
- 5-year warranty

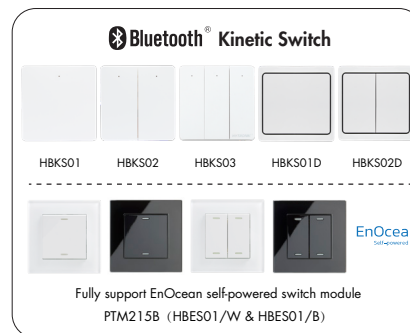

Technical Specifications

Bluetooth Transceiver	
Operation frequency	2.4 GHz - 2.483 GHz
Transmission power	4 dBm
Range (Typical indoor)	10~30m
Protocol	Bluetooth® 5.0 SIG Mesh

Input & Output Characteristics	
Operating voltage	220 ~ 240VAC 50/60Hz
Stand-by power	<1W
Load ratings	400VA (capacitive) 800W (resistive)
Warming-up	30s

Environment	
Operation temperature	Ta: -20°C ~ +50°C
IP rating	IP65

Sensor Data	
Sensor principle	PIR detection
Detection range*	Max installation height: 15m (forklift)
	12m (single person)
	Max detection range: 16m (diameter)
Detection angle	360°

* The detection range is heavily influenced by sensor placement (angle) and different walking paces. It may be reduced under certain conditions.

Safety & EMC	
EMC standard (EMC)	EN55015, EN61547 EN61000-3-2/-3-3
Safety standard (LVD)	EN61347-1, EN61347-2-11
RED	EN300328, EN301489-1 EN301489-17
Certification	ENEC, CE, EMC, LVD, RCM

Mechanical Structure & Dimensions

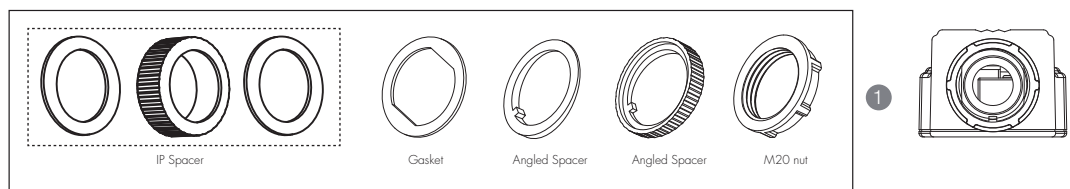
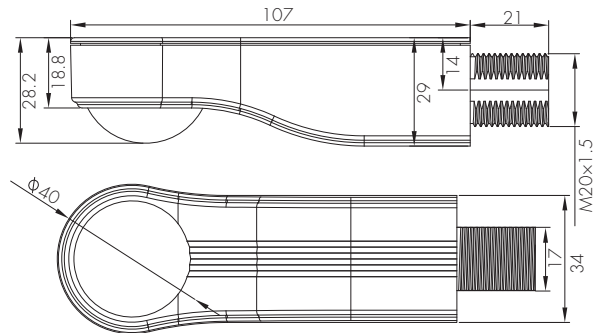
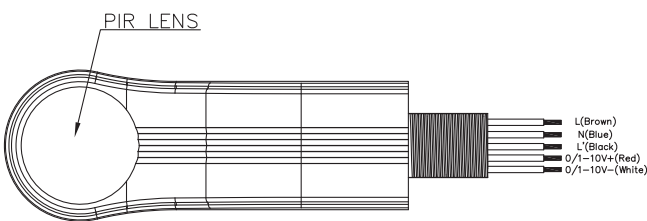

Typical Installation 1

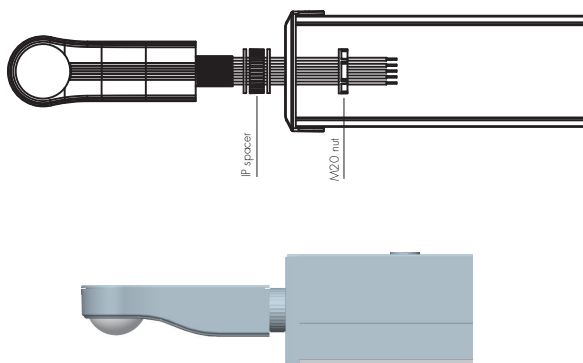

Typical Installation 2

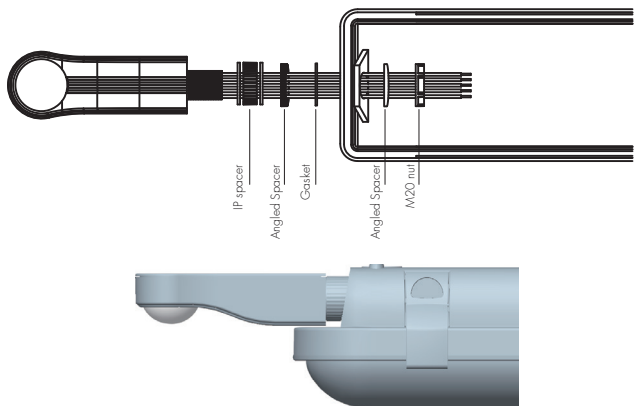

Wiring Diagram

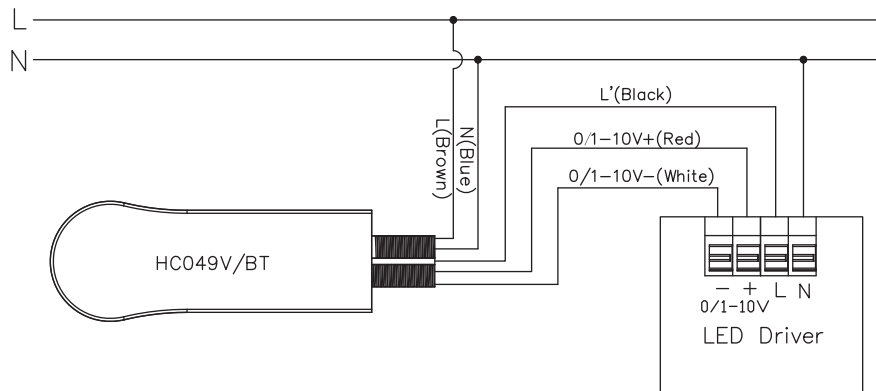

Placement Guide and Typical Range

Smart Phone to Device Range

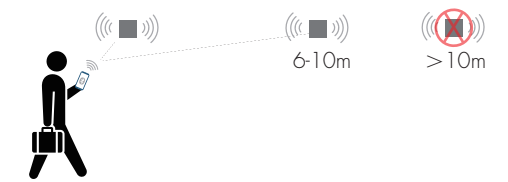

The smart device with the App installed will have a typical range of 10m, but varies from device to device. During commissioning, the installer will need to be in range of the devices when searching for devices to add to the network.

Once the devices have been added to the network via the App, the devices will start communicating within the wireless mesh. This means that once the network is complete, all devices are accessible from the smart device when in a 20m range of a single point.

Detection Pattern

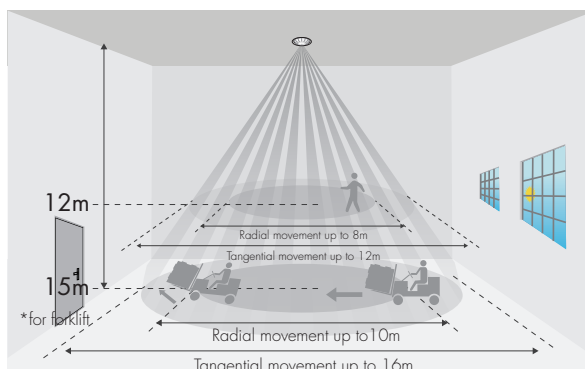

*The detection patterns are based upon 5km/h movement speed.

Additional Information / Documents

1. To learn more about detailed product features/functions, please refer to [www.hytronik.com/download ->knowledge ->Introduction of App Scenes and Product Functions](http://www.hytronik.com/download->knowledge->Introduction%20of%20App%20Scenes%20and%20Product%20Functions)
2. Regarding precautions for Bluetooth product installation and operation, please kindly refer to [www.hytronik.com/download ->knowledge ->Bluetooth Products - Precautions for Product Installation and Operation](http://www.hytronik.com/download->knowledge->Bluetooth%20Products%20-%20Precautions%20for%20Product%20Installation%20and%20Operation)
3. Regarding precautions for PIR sensor installation and operation, please kindly refer to [www.hytronik.com/download ->knowledge ->PIR Sensors - Precautions for Product Installation and Operation](http://www.hytronik.com/download->knowledge->PIR%20Sensors%20-%20Precautions%20for%20Product%20Installation%20and%20Operation)
4. Data sheet is subject to change without notice. Please always refer to the most recent release on [www.hytronik.com/products/bluetooth technology ->Bluetooth Sensors](http://www.hytronik.com/products/bluetooth%20technology->Bluetooth%20Sensors)
5. Regarding Hytronik standard guarantee policy, please refer to [www.hytronik.com/download->knowledge ->Hytronik Standard Guarantee Policy](http://www.hytronik.com/download->knowledge->Hytronik%20Standard%20Guarantee%20Policy)