

## On/off Control HF Sensor

HC005S/I

Against wireless signals interference

# HYTRONIK®

### Applications

Occupancy detector with on/off control suitable for indoor use.

Suitable for building into the fixture:

- Office / Commercial Lighting
- Meeting rooms
- Classroom

Use for new luminaire designs and installations



### Features

- Robust design to prevent wireless signal interference such as Wi-Fi, GSM tower, ultra-high-voltage cable etc
- Special photocell to measure and differentiate natural light from LED light from behind the fixture cover
- Zero crossing detection circuit reduces in-rush current and prolongs relay life
- Loop-in and loop-out terminal for efficient installation
- 5 Year, 50,000hr Warranty

### Technical Data

#### Input Characteristics

Model No.	HC005S/I
Mains voltage	220~240VAC 50/60Hz
Stand-by power	<0.5W
Load ratings:	
Capacitive	400VA
Resistive	800W
Warming-up	20s

#### Safety and EMC

EMC standard (EMC)	EN55015, EN61000
Safety standard (LVD)	EN60669, AS/NZS 60669
Radio Equipment (RED)	EN300440, EN301489, EN301489, EN62479
Certification	Semko, CB, CE, EMC, RED, RCM

#### Sensor Data

Model No.	HC005S/I
Sensor principle	High Frequency (microwave)
Operation frequency	5.8GHz +/- 75MHz
Transmission power	<0.2mW
Detection range (Max.)*	Installation Height : 5m Detection Range(Ø) : 10m@3m height
Detection angle	30° ~ 150°
Setting adjustments:	
Sensitivity	OFF / 30% / 50% / 75% / 100%
Hold-time	5s ~ 30min (selectable)
Daylight threshold	2 ~ 50 lux, disabled

\* For more details of detection range, please refer to "detection pattern" section.

#### Environment

Operation temperature*	Ta: -35°C ~ +70°C
Case temperature (Max.)	Tc: +80°C
IP rating	IP20

\*For usage in -35°C ~ -20°C environment, please refer to [www.hytronik.com/download->knowledge](http://www.hytronik.com/download->knowledge)  
->Microwave Sensors - Precautions for Product Installation and Operation point 4) for more information.

CE emc RED CB IP20

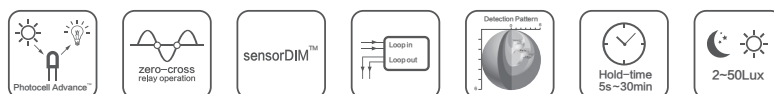
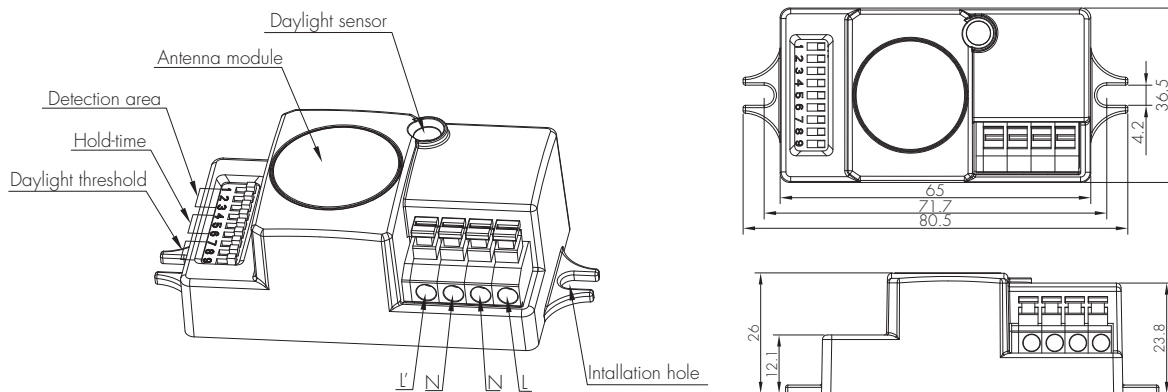

## Functions and Features

### 1 On/off Control with Photocell Advance™ Function

This sensor is a motion switch, which turns on the light upon detection of motion, and turns off after a pre-selected hold-time when there is no movement.

Furthermore, a Hytronik specially designed photocell is also built in to switch on/off the light based upon ambient natural light lux level. It's well known that LED lights have a totally different spectrum from natural light. Hytronik uses this principle and comes up with this special photocell and sophisticated software algorithm to measure and differentiate natural light from LED light from behind the fixture cover, so that this photocell can ignore internal LED light and only respond to the natural light outside.

Our technology has no infringement to the existing patents in the market.

#### Settings on this demonstration:

Hold-time: 30min      Daylight threshold: 50lux

Insufficient natural light and motion detection: light ON

Sufficient natural light or no motion after hold-time: light OFF

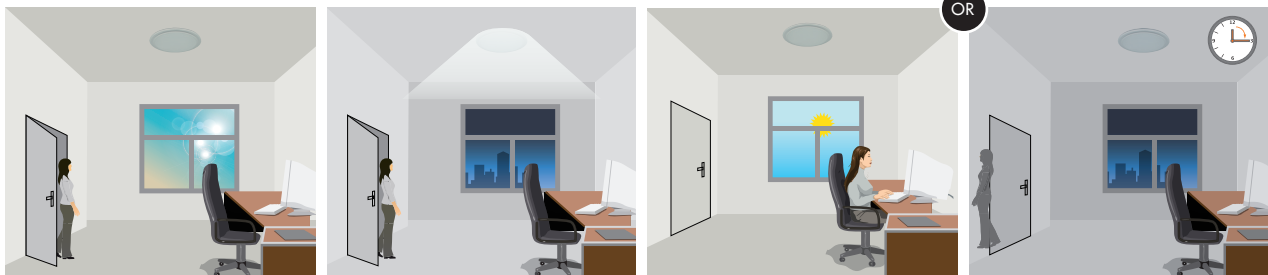

With sufficient natural light, the light does not switch on when presence is detected.

With insufficient natural light, the sensor switches on the light when presence is detected.

The sensor switches off the light whenever natural light exceeds pre-set daylight threshold, even with presence.

The sensor switches off the light after the hold-time when there is no motion detected.

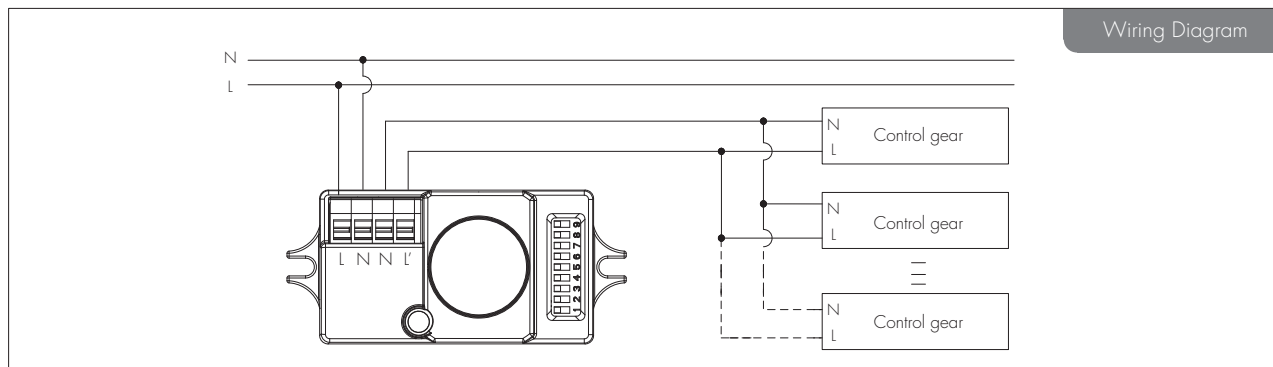

## 2 Zero-cross Relay Operation

Designed in the software, sensor switches on/off the load right at the zero-cross point, to ensure that the in-rush current is minimised, enabling the maximum lifetime of the relay.

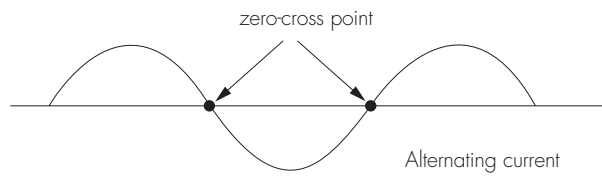

## 3 Loop-in and Loop-out Terminal

Double L N terminal makes it easy for wire loop-in and loop-out, and saves the cost of terminal block and assembly time.

## 4 SensorDIM™ Function

Working with Switch-dim. control gear (Excel ballast/driver, corridor function), this sensor can also achieve tri-level control.

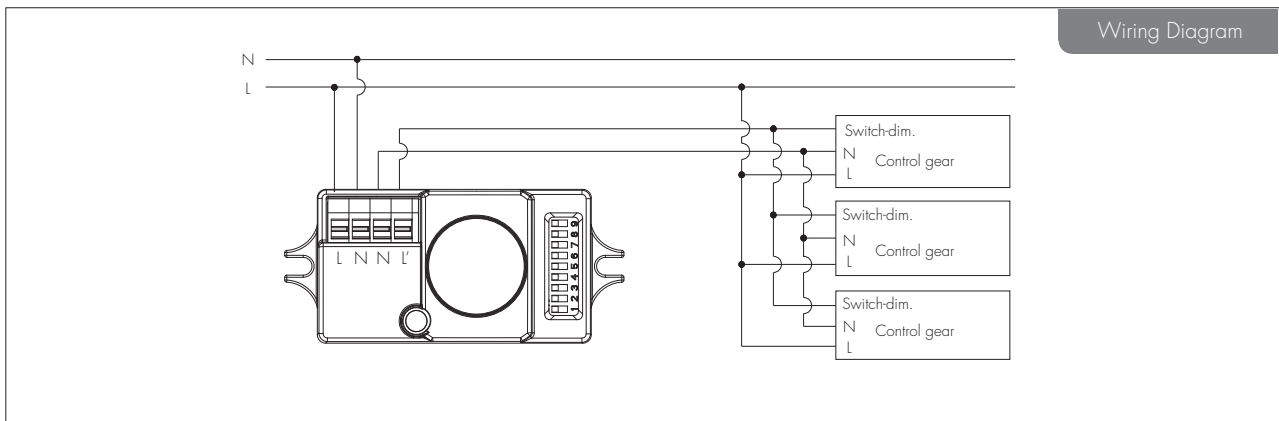

## Detection Pattern

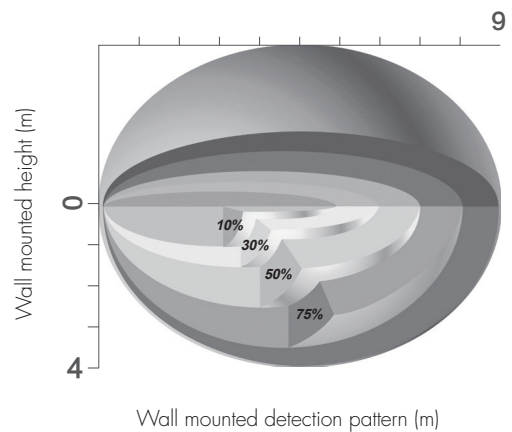
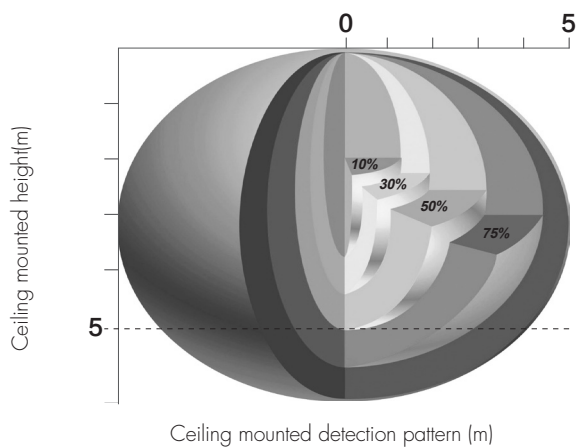

# “Robust” HF Sensors — Anti-wireless Interference



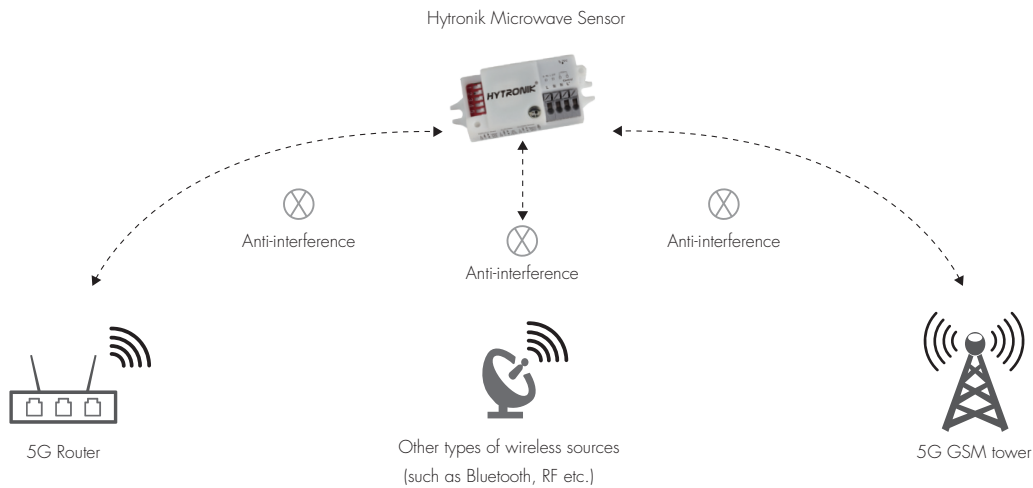

Hytronik’s microwave motion sensor uses 5.8GHz high frequency (HF) antenna in the product design. With the increasing density of wireless environments such as 5G GSM tower and 5G Wi-Fi coverage, this has created extra challenges for sensor’s operation because the air is shared by all kinds of wireless signals, and transmissions from any device at the similar frequency could potentially cause interference. The effects of interference which can be noticed by users are usually false triggering of sensors (turning on/off erratically), or lights staying on even after hold time etc.

To get around such tough environment, Hytronik has developed a robust HF module, loaded with our own special sophisticated software algorithms. This robust HF module can withstand different types of wireless interferences in the real application. We believe this is the ultimate solution towards demanding installation environments in the future.



Thanks to the improved resistance against wireless interference, the robust HF module is compliant to the latest RED standards.

With this powerful antenna adapted in our microwave sensors, it ensures stable and accurate performance even when installed in tough wireless environments.

	5G Wi-Fi Interference 	5G GSM Tower Interference 	Bluetooth Interference 	RF Interference 
Hytronik's new robust HF sensors <b>NEW!</b>	High resistance	High resistance	High resistance	High resistance
Traditional normal HF sensors	Low resistance	Low resistance	Low resistance	Low resistance

## DIP Switch Settings

### 1 Detection Range

Sensor sensitivity can be adjusted by selecting the combination on the DIP switches to fit precisely for each specific application.

Disabling the motion detection function will put the sensor into photocell only mode.

	1	2	3	
I	●	●	●	100%
II	○	●	●	75%
III	○	●	○	50%
IV	○	○	●	30%
V	○	○	○	Sensor OFF



I – 100%  
 II – 75%  
 III – 50%  
 IV – 30%  
 V – Sensor OFF

### 2 Hold Time

Select the DIP switch configuration for the light on-time after presence detection. This function is disabled when natural light is sufficient.

	4	5	6	
I	●	●	●	5s
II	●	○	●	30s
III	●	○	○	1min
IV	○	●	●	5min
V	○	●	○	10min
VI	○	○	●	20min
VII	○	○	○	30min



I – 5s  
 II – 30s  
 III – 1min  
 IV – 5min  
 V – 10min  
 VI – 20min  
 VII – 30min

### 3 Daylight Threshold

Set the level according to the fixture and environment. The light will not turn on if ambient lux level exceeds the daylight threshold preset. In Photocell Advance™ mode this level will determine at which point the light turns off. *Please note that the ambient lux level refers to internal light reaching the sensor.*

Disabling the daylight sensor will put the sensor into occupancy detection only mode.

	7	8	9	
I	●	●	●	Disable
II	○	●	●	50Lux
III	○	●	○	20Lux
IV	○	○	●	5Lux
V	○	○	○	2lux



I – Disable  
 II – 50 Lux  
 III – 20 Lux  
 IV – 5 Lux  
 V – 2 Lux