

Bluetooth® Kinetic Switch

HBKS02/W

A two-gang Switch

HYTRONIK®



Product Description

HBKS02 series is a two-button Bluetooth kinetic switch (self-powered), with a lifespan of 100,000 repeated presses, and available in black and white. It requires no batteries or wiring, offering the flexibility to be freely placed or adhered to according to the needs. Moreover, HBKS02 series features "short press" and "long press" button combinations, allowing to achieve dimming control, scene recall, and quit manual mode through the **Koolmesh**® app. All simple device setup and commissioning can be done via the **Koolmesh**® app.



App Features

Single Short Press

1. On/Off control
2. Scene recall
3. Quit manual mode

Press And Hold

1. Dimming control
2. Colour tuning (Warm to Cool White)

Hardware Features

- Self powered
- Without battery
- Without wiring
- Freely placeable
- Waterproof (no electric shock)
- Key indicator light

Smartphone app for both iOS & Android platform

Koolmesh Pro app for iPad

Web app/platform: www.iot.koolmesh.com

Technical Specifications & Dimensions

Bluetooth Transceiver	
Operation frequency	2.4 GHz - 2.483 GHz
Transmission power	0 dBm
Range (Typical indoor)	10~30m
Protocol	Bluetooth®

Overview	
Power supply	Self-powered (kinetic energy)
Channels	2 (twogang)
Mounting	Adhesive pad option is being supplied in the box, for use on smooth surfaces only
Lifetime	100,000 actuation (switching cycles)
Housing material	PC
Switch pressing force	≤700g (reference only, individual variations exist)
Dimensions	86 x 86 x 1.5mm
Operation temperature	Ta: -10°C ~ +40°C

Mechanical Structure & Dimensions

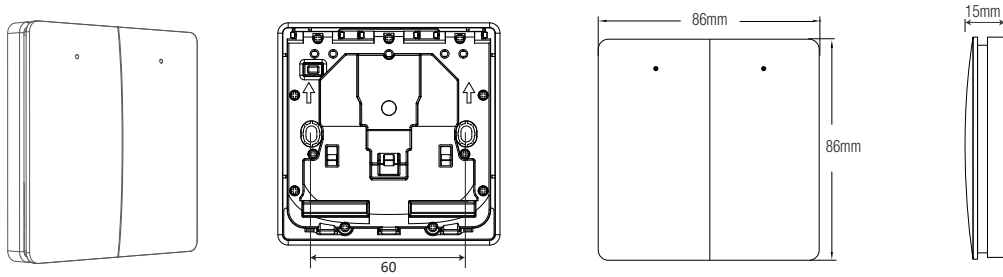

Optional Accessories For Switch Bezel

The Switch Bezel is an accessory for Hytronik kinetic switches in Basalt Grey. It enhances accessibility, especially for those with impaired vision or limited hand mobility. Compliant with the UK's Part M regulations, it ensures safe and easy usage for everyone.

HAKS01/W, HAKS01/B (size:mm)

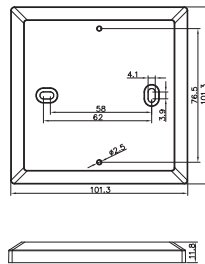

For the installation of a single switch

HAKS02/W, HAKS02/B (size:mm)

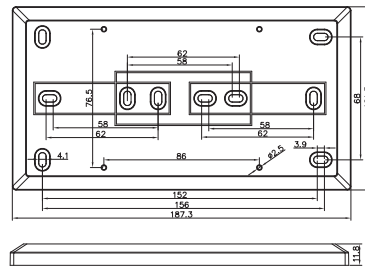

For the installation of double switches

Method 1: Adhesive Mounting

*If the wall surface is clean and smooth, directly peel off the double-sided adhesive tape and stick the switch to the wall.

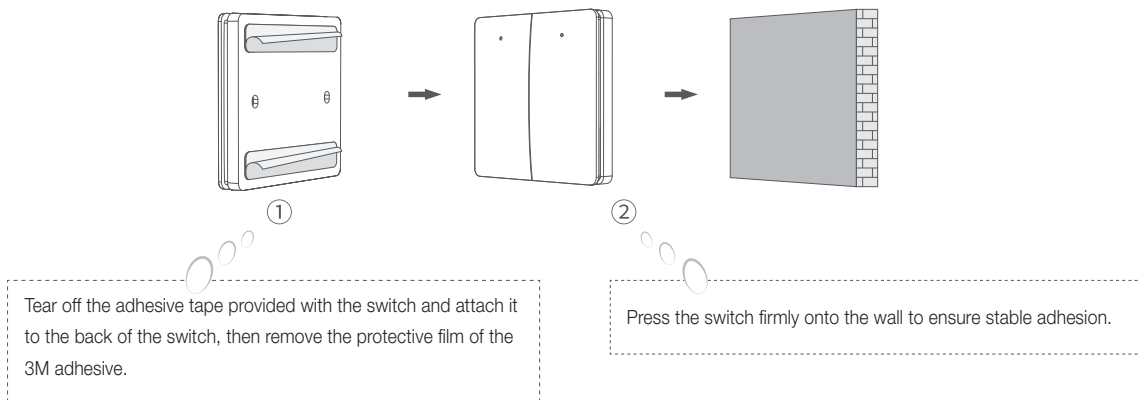

Method 2: Installation with Original Switch Box

*If prefer to install it on the original switch box, use screws for installation.

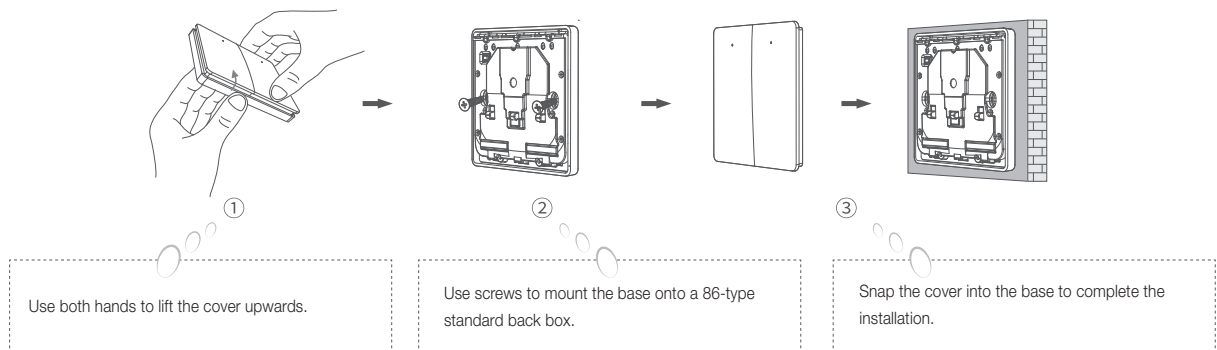

Method 3: Installation with Switch Bezel

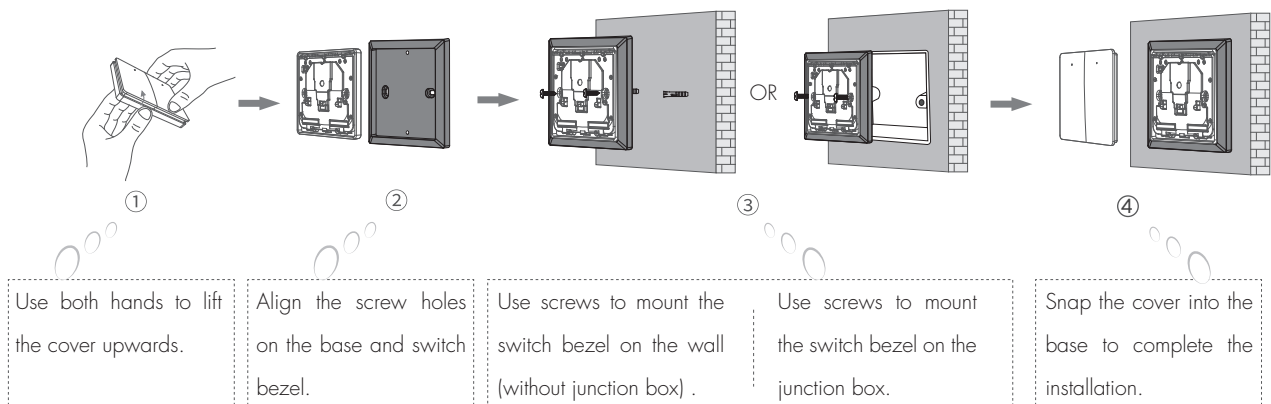

Dimming Interface Notes

Detailed Push switch configurations can be set on Koolmesh app.

Switch Function	Action	Descriptions
Push switch	Short press (<1 second) * Short press has to be longer than 0.1s, or it will be invalid.	- Turn on/off - Turn on only - Turn off only - Recall a scene - Quit manual mode - Do nothing
	Long press (≥ 1 second)	- Dimming - Colour tuning (Warm to Cool White) - Do nothing

Additional Information / Documents

1. To learn more about detailed product features/functions, please refer to [www.hytronik.com/download ->knowledge ->Introduction of App Scenes and Product Functions](http://www.hytronik.com/download->knowledge->Introduction%20of%20App%20Scenes%20and%20Product%20Functions)
2. Regarding precautions for Bluetooth product installation and operation, please kindly refer to [www.hytronik.com/download ->knowledge ->Bluetooth Products - Precautions for Product Installation and Operation](http://www.hytronik.com/download->knowledge->Bluetooth%20Products%20-%20Precautions%20for%20Product%20Installation%20and%20Operation)
3. Data sheet is subject to change without notice. Please always refer to the most recent release on [www.hytronik.com/products/bluetooth technology ->Bluetooth Accessories](http://www.hytronik.com/products/bluetooth%20technology->Bluetooth%20Accessories)
4. Regarding Hytronik standard guarantee policy, please refer to [www.hytronik.com/download ->knowledge ->Hytronik Standard Guarantee Policy](http://www.hytronik.com/download->knowledge->Hytronik%20Standard%20Guarantee%20Policy)