

Integrated LED Driver + Microwave Sensor with Bluetooth® 5.0 SIG Mesh

HBE9028

Constant Current

HYTRONIK®



Product Description

HBE9028 is integrated Bluetooth dimming LED driver + microwave sensor combo with maximum power output of 28W. Such 2 in 1 integrated design is a very cost-effective solution, it is ideal for new luminaires design for lighting manufacturers. It comes with Switch-Dim interface by using Push switch (retractive switch) and of course Bluetooth dimming interface. With Bluetooth wireless mesh networking, it makes communication between luminaires much easier without time-consuming hardwiring, which eventually saves costs for projects. Meanwhile, simple device setup and commissioning can be done via **Koolmesh™** app.



App Features

- Quick setup mode & advanced setup mode
- Web app/platform for project deployment & data analysis
- Koolmesh Pro app on iPad for on-site configuration
- Floorplan feature to simplify project planning
- One-key device replacement
- Device social relations check
- Staircase function (primary & secondary)
- Remote control via gateway support HBGW01
- Heat map
- Dynamic daylight harvest auto-adaptation
- Grouping luminaires via mesh network
- Scenes
- Dusk/Dawn photocell (Twilight function)
- Tri-level control
- Daylight harvest
- Circadian rhythm (Human centric lighting)
- Push switch configuration
- Detailed motion sensor settings
- Schedule
- Astro timer (sunrise and sunset)
- Power-on status (memory against power loss)
- Offline commissioning
- Bulk commissioning (copy and paste settings)
- Different permission levels via authority management
- Network sharing via QR code or keycode
- Interoperability with Hytronik Bluetooth product portfolio

- Compatible with EnOcean BLE switches
- Internet-of-Things (IoT) featured
- Device firmware update over-the-air (OTA)
- Continuous development in progress...

Hardware Features

- Photocell Advance
- Switch-Dim with one Push input
- Insulated terminal cover with cord restraint
- Standby power < 1W
- Analogue flicker-free dimming
- Over-temperature Protection
- Short-circuit Protection
- Overload Protection
- 5-year warranty, designed for long lifetime up to 50,000 hours

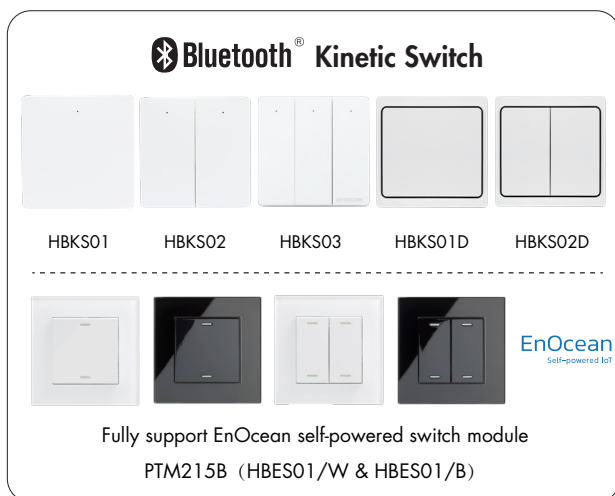

Bluetooth 5.0 SIG mesh

HYTRONIK
Koolmesh

iOS
Android

for iOS for Android

Smartphone app for both iOS & Android platform

for iPad

Koolmesh Pro app for iPad

Web

for Web

Web app/platform: www.iot.koolmesh.com

Technical Specifications

Bluetooth Transceiver	
Operation frequency	2.4 GHz - 2.483 GHz
Transmission power	4 dBm
Range (Typical indoor)	10~30m
Protocol	Bluetooth® 5.0 SIG Mesh

Sensor Data	
Sensor principle	High Frequency (microwave)
Operation frequency	5.8GHz +/- 75MHz
Transmission power	<0.2mW
Detection range (Max.)*	Installation Height : 6m Detection Range(Ø) : 10m@3m height
Detection angle	30°~ 150°

Safety & EMC	
EMC standard (EMC)	EN55015, EN61547, EN6100-2/3
Safety standard (LVD)	EN61347-1, EN61347-2-13
RED	EN300328, EN300440, EN301489-1 EN301489-3, EN301489-17
Dielectric strength	Input→output: 3000VAC / 5mA / 1min
Abnormal protection	Output short-circuit protection
Certification	CB, CE, EMC, RED, RCM, UKCA

Input Characteristics	
Operating voltage	220~240VAC 50/60Hz
Input current	0.150 - 0.140A
Input power	33W (Max.)
Warming-up	20s

Driver Data	
Off load voltage	60V
Output LED current / voltage / power	300mA/6-47V/2-14W 350mA/6-47V/2-16.5W 400mA/6-47V/2-19W 450mA/6-47V/3-21W 500mA/6-47V/3-23.5W 550mA/6-47V/3-26W 600mA/6-45V/4-27W 650mA/6-42V/4-27W 700mA/6-40V/4-28W
Power factor	>0.9
Efficiency	85% (Max.)

Environment	
Operation temperature	Ta: -20°C ~ +50°C
Case temperature (Max.)	Tc: +75°C
IP rating	IP20

Mechanical Structure & Dimensions

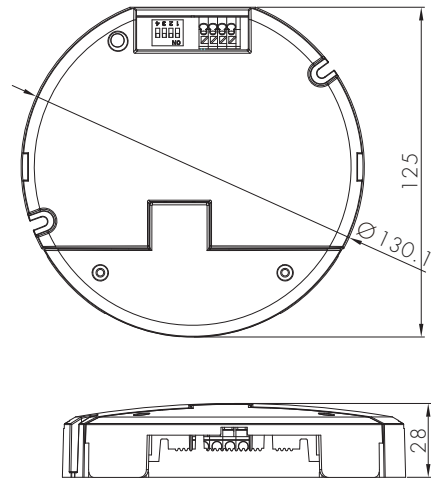
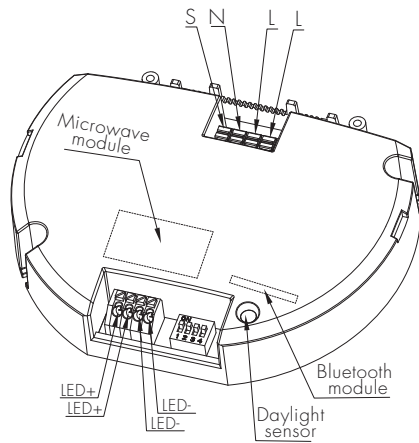

Wire Preparation

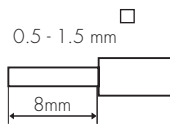
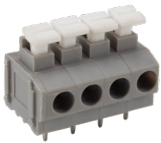

To make or release the wire from the terminal, use a screwdriver to push down the button.

Wiring Diagram

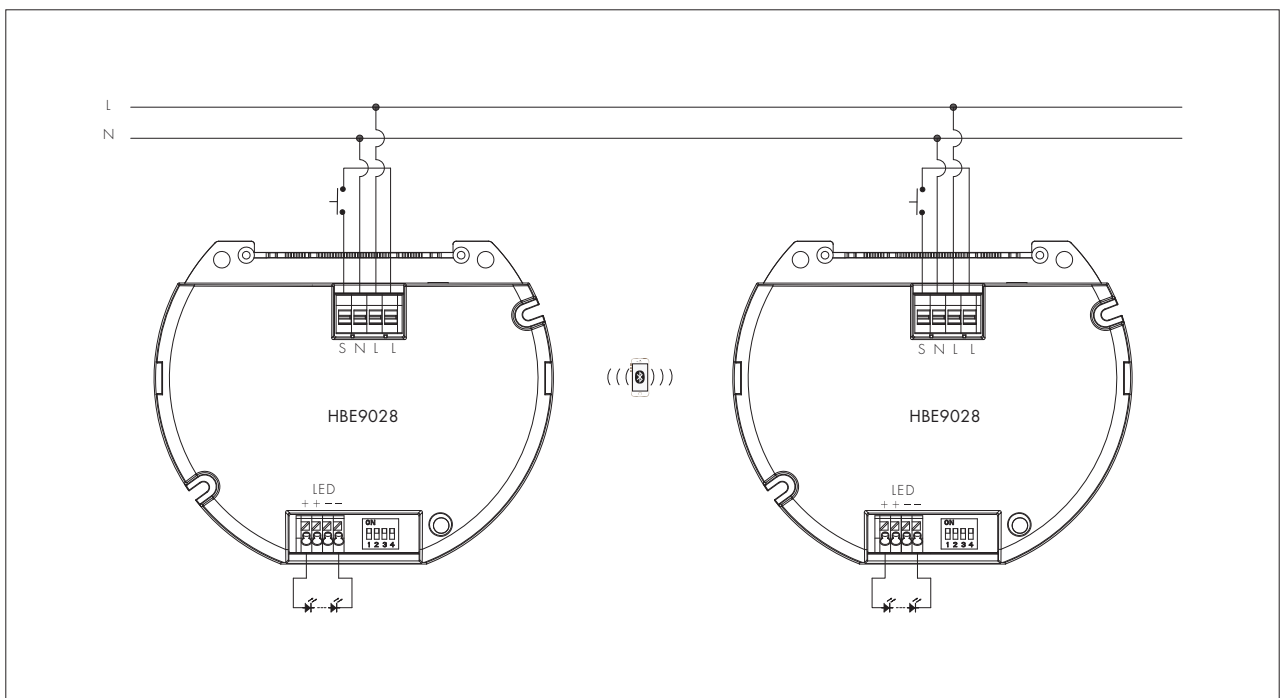

Assembly



The sensor features the DIP switches and protrudes the LED panel. This feature enables the end user to select current without removing the gear tray / LED board.

Loading and In-rush Current

Model	HBE9028
In-rush Current (Imax.)	15A
Pulse Time	70µs

Output Configuration

700mA	●●●●
650mA	○●●●
600mA	●○●●
550mA	●●●○
500mA	○●●○
450mA	●●○○
400mA	○●○○
350mA	●○○○
300mA	○○○○

1 2 3 4

Circuit Breaker Information

Automatic circuit breaker type	B16A	B10A	B13A	B20A	B25A
HBE9028	66	41	54	83	104

The data above is calculated according to the formula: Maximum Amount = $16 / (P_n / 230)$. In order to provide a more reliable reference in real application, the data have been revised to take 60% of the number calculated, i.e. $16 / (P_n / 230) \times 60\%$. Please kindly take note that the calculation is based on ABB circuit breaker series S200. Actual values may differ due to different types of circuit breaker used and installation environment.

Detection Pattern

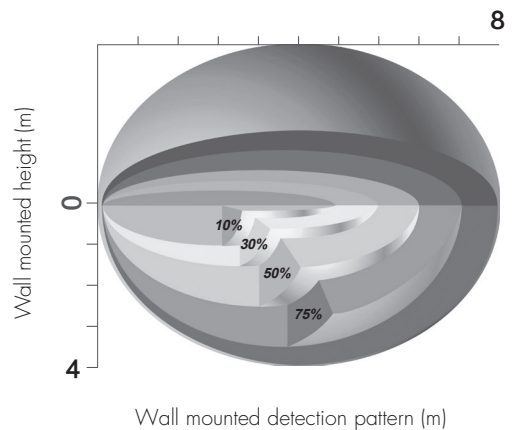
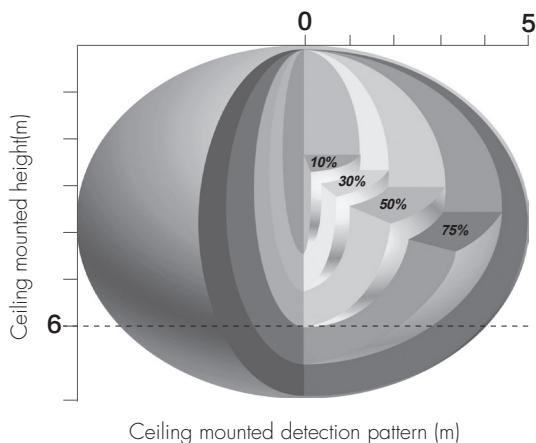

Performance Characteristics

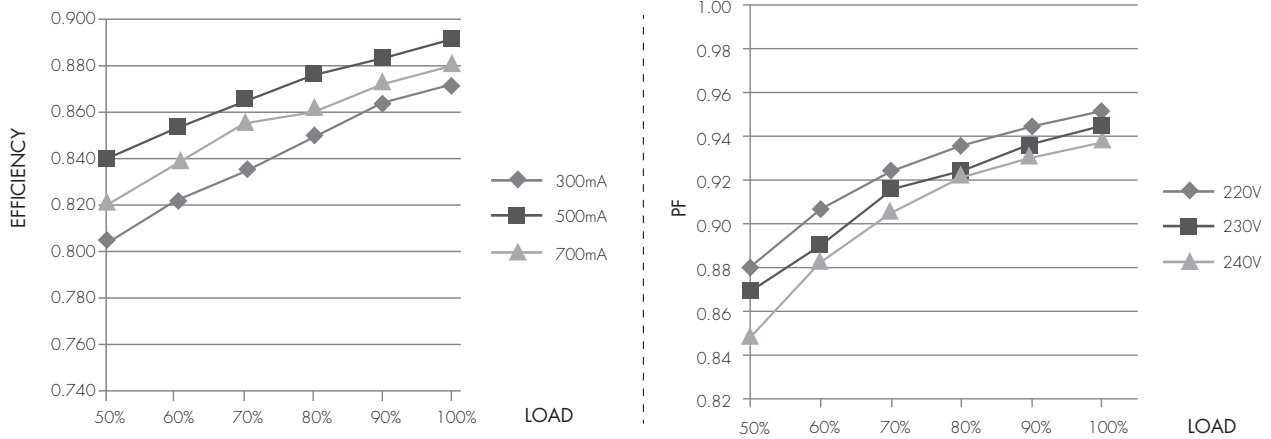

Dimming Interface Operation Notes

Switch-Dim

The provided Switch-Dim interface allows for a simple dimming method using commercially available non-latching (momentary) wall switches. Detailed Push switch configurations can be set on Koolmesh app.

Switch Function	Action	Descriptions
Push switch	Short press (<1 second) * Short press has to be longer than 0.1s, or it will be invalid.	- Turn on/off - Recall a scene - Turn on only - Quit manual mode - Turn off only - Do nothing
	Double push	- Turn on only - Quit manual mode - Turn off only - Do nothing - Recall a scene
	Long press (≥ 1 second)	- Dimming - Colour tuning - Do nothing
Sensor-link	/	- Upgrade a normal on/off motion sensor to a Bluetooth controlled motion sensor
Emergency Self-Test Function	Short press (<1 second) * Short press has to be longer than 0.1s, or it will be invalid.	- Start Self test (Monthly) - Stop Self test - Start Self test (Annually) - Invalid
	Long press (≥ 1 second)	- Start Self test (Monthly) - Stop Self test - Start Self test (Annually) - Invalid
Fire Alarm (VFC signal only)	Refer to Koolmesh™ App User Manual V2.1	- Able to connect the Fire Alarm system - Once the fire alarm system is triggered, all the luminaries controlled by the Push Switch will enter the preset scene (normally it's full on), after the fire alarm system gives the ending signal, all the luminaries controlled by this Push Switch will revert back to normal status.

Additional Information / Documents

1. For full explanation of Hytronik Photocell Advance™ technology, please kindly refer to www.hytronik.com/download ->knowledge ->Introduction of Photocell Advance
2. To learn more about detailed product features/functions, please refer to www.hytronik.com/download ->knowledge ->Introduction of App Scenes and Product Functions
3. Regarding precautions for Bluetooth product installation and operation, please kindly refer to www.hytronik.com/download ->knowledge ->Bluetooth Products - Precautions for Product Installation and Operation
4. Regarding precautions for microwave sensor installation and operation, please kindly refer to www.hytronik.com/download ->knowledge ->Microwave Sensors - Precautions for Product Installation and Operation
5. Regarding precautions for LED driver installation and operation, please kindly refer to www.hytronik.com/download ->knowledge ->LED Drivers - Precautions for Product Installation and Operation
6. Data sheet is subject to change without notice. Please always refer to the most recent release on [www.hytronik.com/products/bluetooth technology](http://www.hytronik.com/products/bluetooth%20technology) ->Bluetooth Drivers
7. Regarding Hytronik standard guarantee policy, please refer to www.hytronik.com/download ->knowledge ->Hytronik Standard Guarantee Policy