

QCB03/4WAY

DALI & 0/1-10V Output

Product Description

GST type 6-pole terminal base quick connection box for dimming application, with DALI or 0/1-10V output, 4 luminaire outlets and 1 sensor outlet. Freely switch between 1-channel and 2-channel. Rating of system 16A, rating of each output 10A.

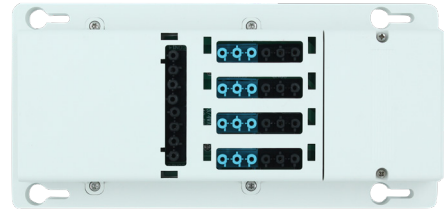

Key Features

- Dimmable control applications (DALI-2 or 0/1-10V)
- 4 luminaire outlets + 1 extra sensor outlet for sensor connection
- Luminaire outlet: GST type 6-pole terminal base (L' or L, E, N, Em, Dim-, Dim+)
- Sensor outlet: GST type 8-pole terminal base (L, E, N, L', P1, P2, Dim-, Dim+)
- Black housing and white housing available to choose from
- Freely switch between 1-channel (1 x 4) & 2-channel (2 x 2) control
- Tamper-proof structure design
- Expandable: easy extension to another QCB03/4WAY via plug' n' play
- Rating of system: Max 16A. Rating of each output: Max 10A
- Flame-retardant material for safety protection

Your Benefits

- Five types of installation methods meets different project needs
- Reduce labour hours and labour cost significantly
- Simple and intuitive wiring connections
- Improved safety level during wiring operations
- Clear and clean wiring makes it easy for future maintenance
- Can be supplied with pre-wired cables

Technical Specifications

Mains voltage	220~240VAC 50/60Hz
Rated load	Rating of system 10A. Rating of each output 10A
Terminal capacity	0.75 - 4.0mm ² (max. 2 x 2.5mm ²)
Storage temperature	-20°C ~ +60°C
Max. relative humidity	20 ~ 90%
Insulation	Class II

Mechanical Structure & Dimensions

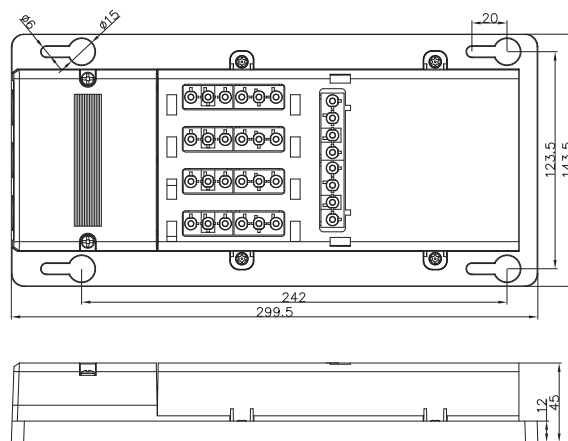
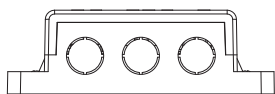
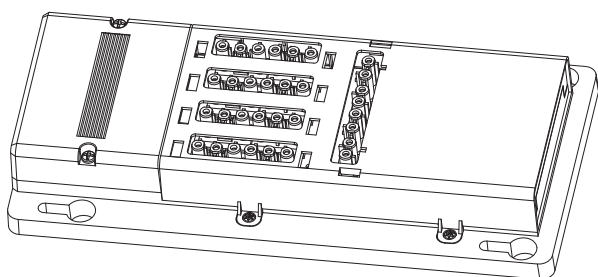
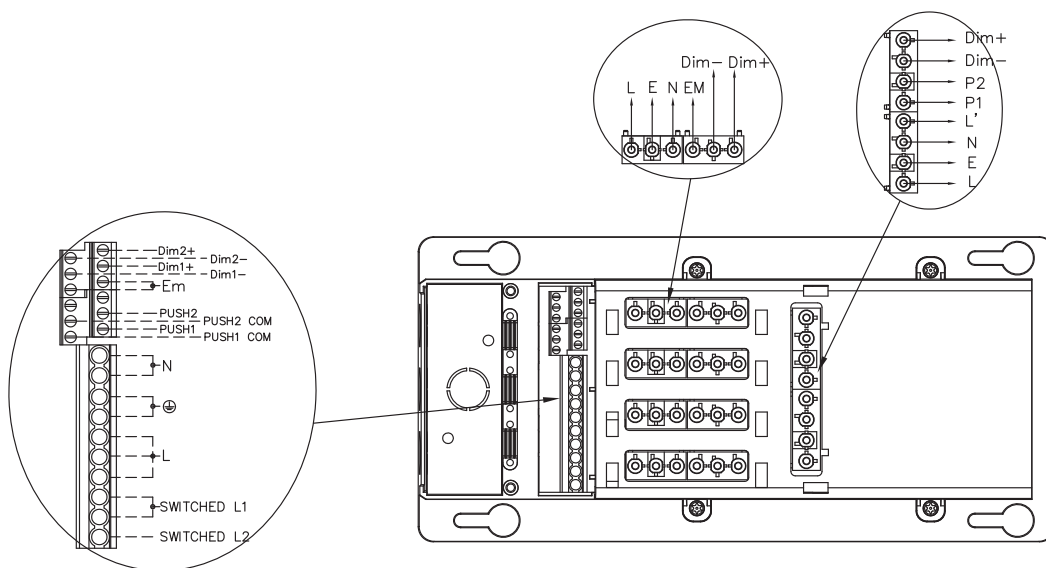
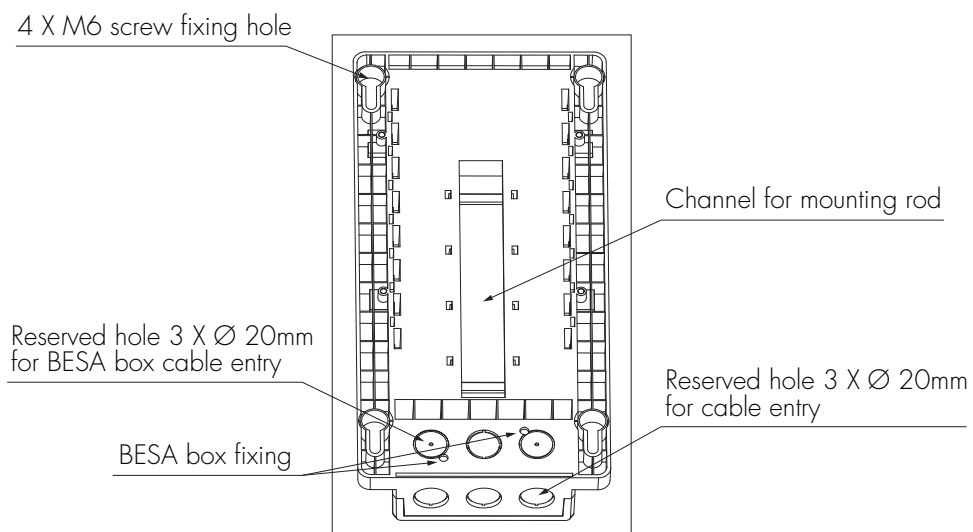

Input & Output Terminal Function

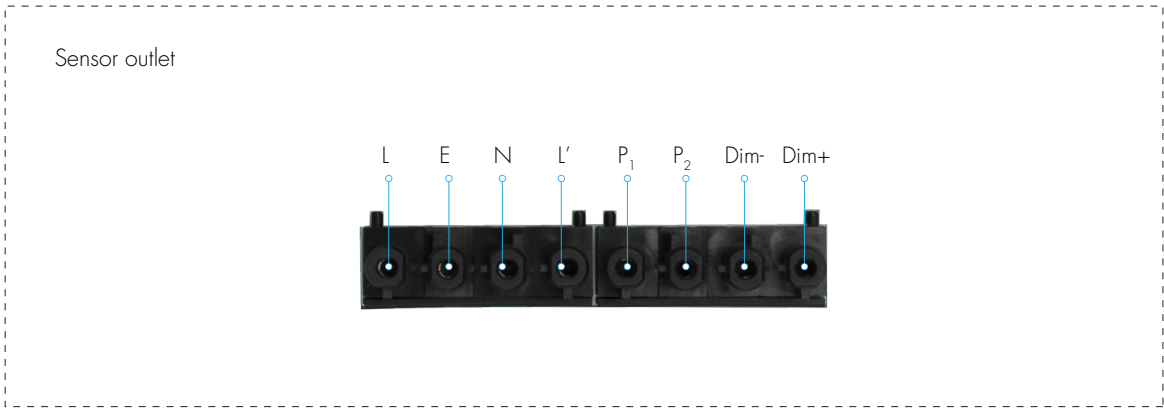
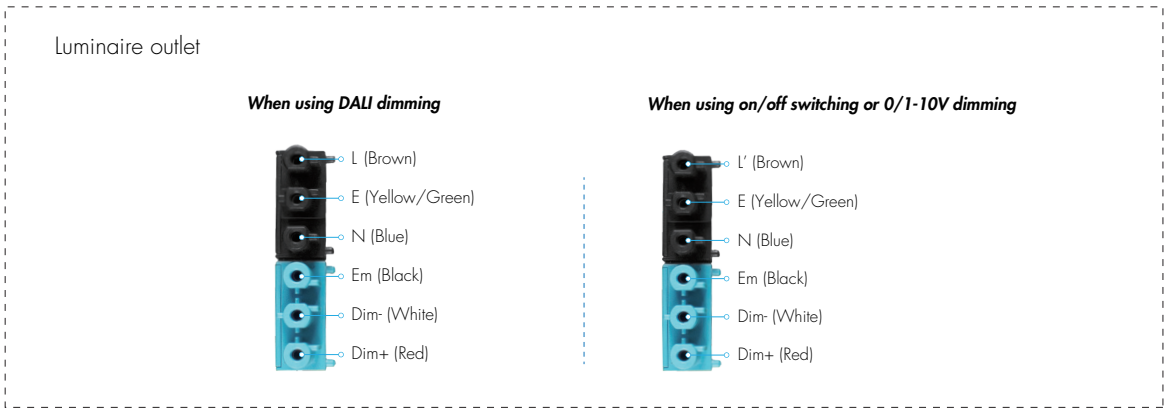
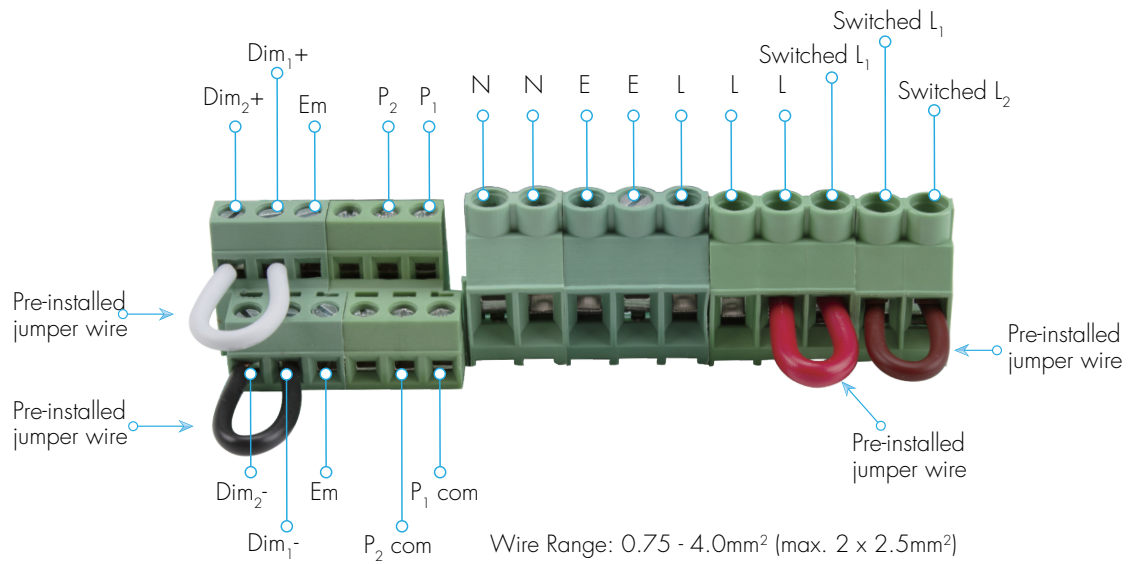

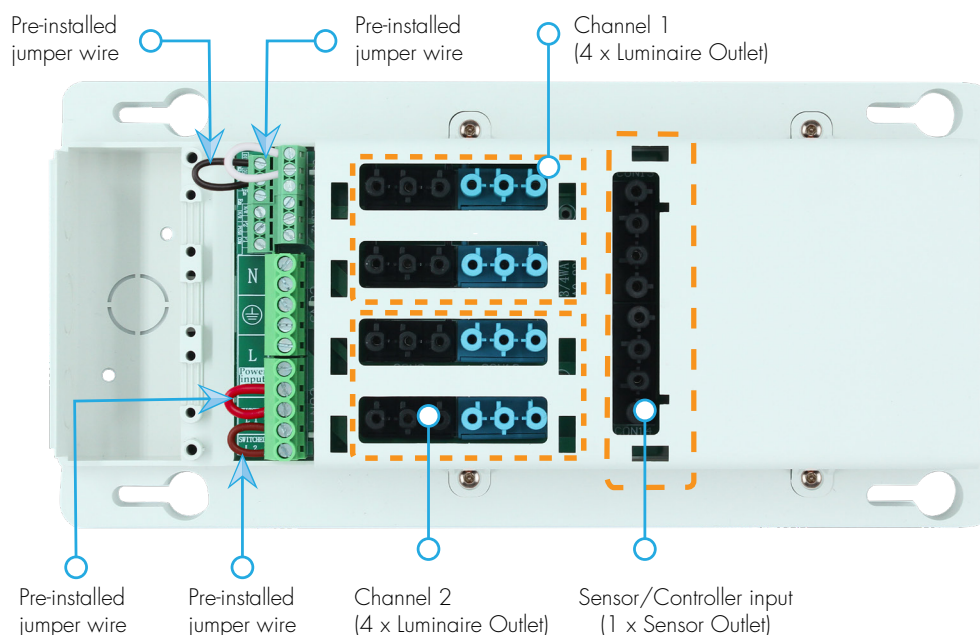

Factory default for QCB03/4WAY comes with four pre-installed jumper wires. The brown wire short-connects Switched L1 and Switched L2 together, the red jumper wire short-connects Switched L and L, the black jumper wire short-connects Dim1- and Dim2-, and the white jumper wire short-connects Dim1+ and Dim2+. With these jumper wires, user can freely choose different dimming control method and also freely switch between one-channel and two-channel control.

- 1) one-channel (1 x 4) DALI dimming --- keep all four jumper wires.
- 2) two-channel (2 x 2) dual DALI dimming -- keep red wire & brown wire, remove black wire & white wire.
In this case the two channels will be controlled separately (channel 1 is controlled by Dim1+ & Dim1-, and channel 2 is controlled by Dim2- & Dim2+).
- 3) one-channel (1 x 4) 0/1-10V dimming --- remove red wire, keep brown wire & black wire & white wire.
- 4) two-channel (2 x 2) dual 0/1-10V dimming --- remove all four jumper wires.
In this case the two channels will be controlled separately (channel 1 is controlled by Switched L1, Dim1+ & Dim1-, and channel 2 is controlled by Switched L2, Dim2- & Dim2+).
- 5) two-channel (2 x 2) DALI dimming + on/off switching -- keep red wire, remove brown wire & black wire & white wire.
In this case the two channels will be controlled separately (channel 1 is controlled by Dim1+ & Dim1-, and channel 2 is controlled by Switched L2).
- 6) two-channel (2 x 2) 0/1-10V dimming + on/off switching --- remove all four jumper wires.
In this case the two channels will be controlled separately (channel 1 is controlled by Dim1+ & Dim1-, and channel 2 is controlled by Switched L2).

This flexible design aims to reduce model inventories for users, and just one box is capable enough to handle different dimming requirements on the project site. Easy for management, and powerful for usage!

Installation methods

Surface Mount ▼

It can work with 4 x M6 screws to fix onto both walls and ceilings.

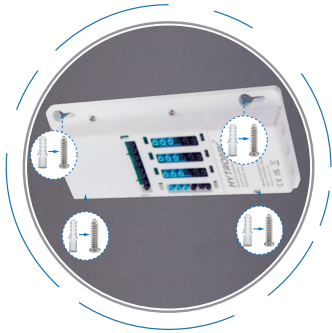

BESA/Junction Box Connection ▼

It can be connected with BESA/junction box.

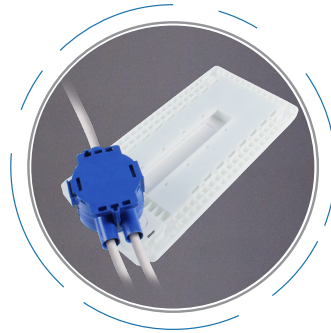

Channel Nut Mount ▼

It can work with channel nuts to fasten into the back.

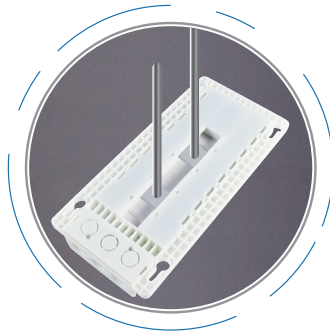

Mounting Rods ▼

It can be fixed with mounting rods.



Marco Tray Mount ▼

It can work with Marco clips steel wire cables tray system.

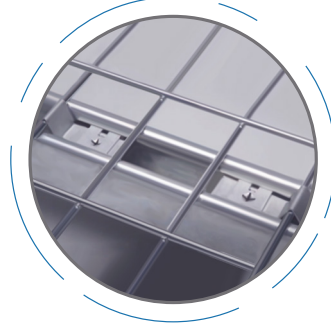

Minimum Installation Height

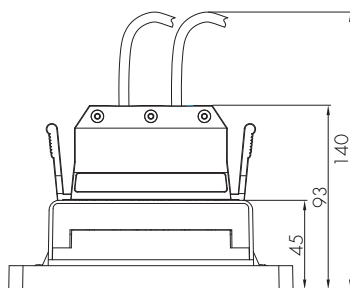

Sensor plug (HP06)

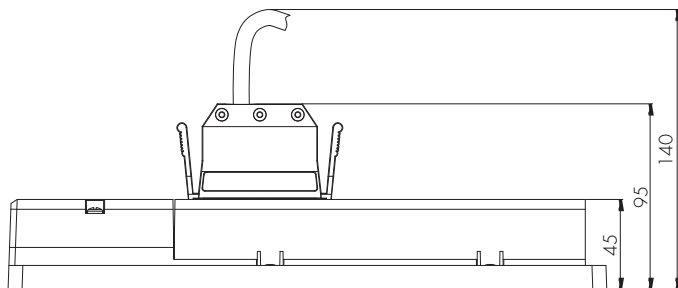

Luminaire plug (HP03)

Note: The minimum height for total height of unit is 140mm(including connectors and cables).

Wiring Diagram

---This product should be installed by a qualified electrician.

Factory default setting with four pre-installed jumper wires
 One-channel (1x4) DALI dimming control

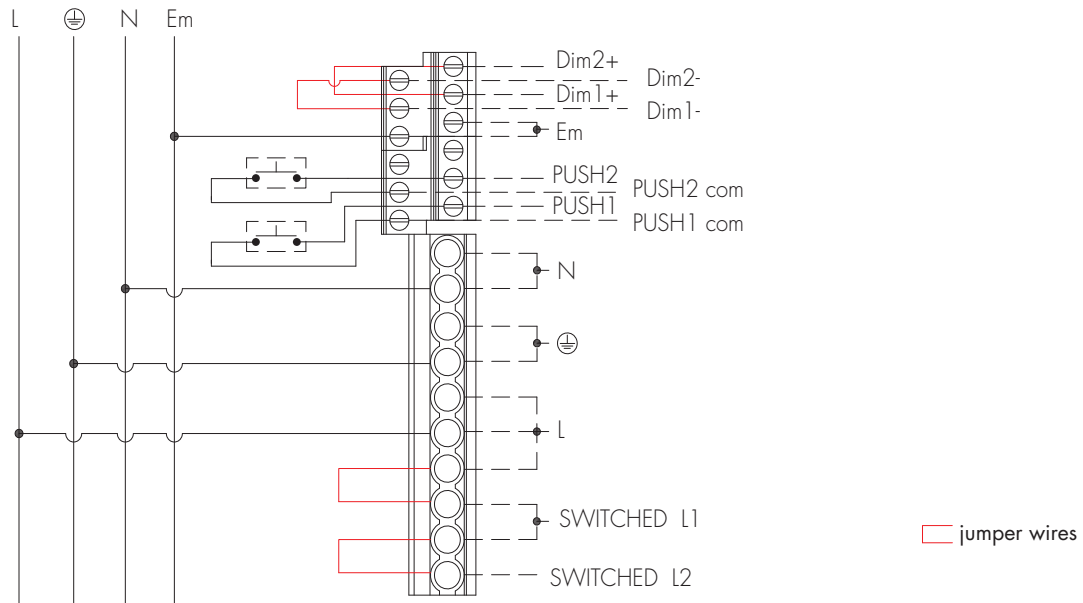

- Note: 1. By removing different jumper wires, users can achieve different dimming/switching control.
 2. Do not wire across phases.

Wiring & Emergency Test

Local lighting switch and local emergency test switch

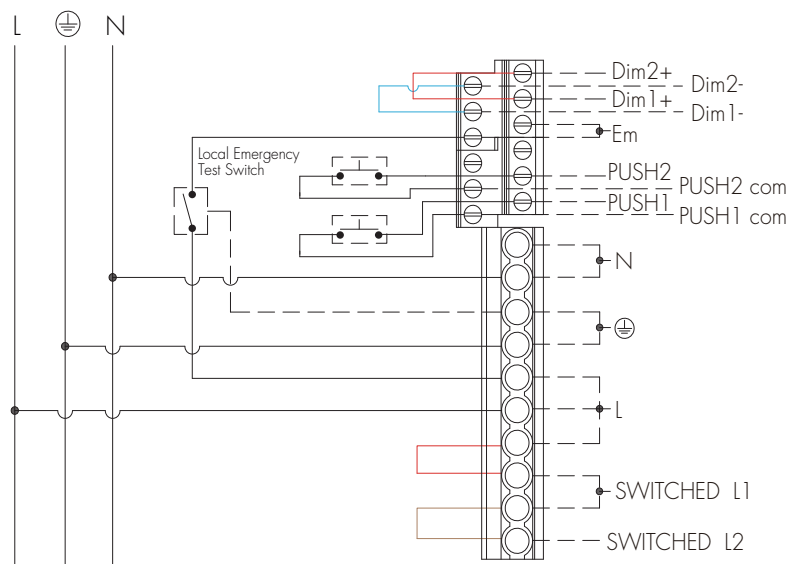

Note: Do not wire across phases.

Using Local lighting switch for power interruption

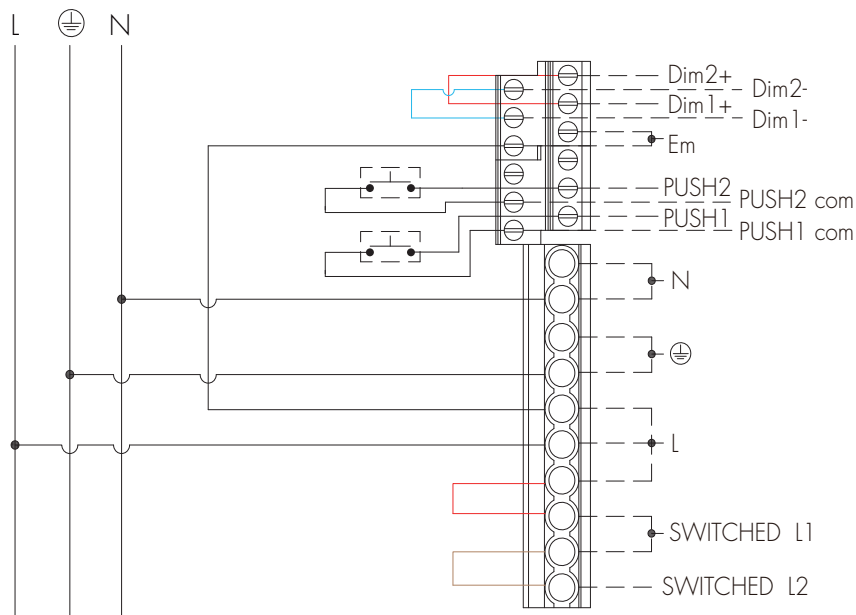

- Note: 1. A local lighting switch may still be used when there is a central emergency test switch.
 2. Do not wire across phases.

Emergency test using central switch

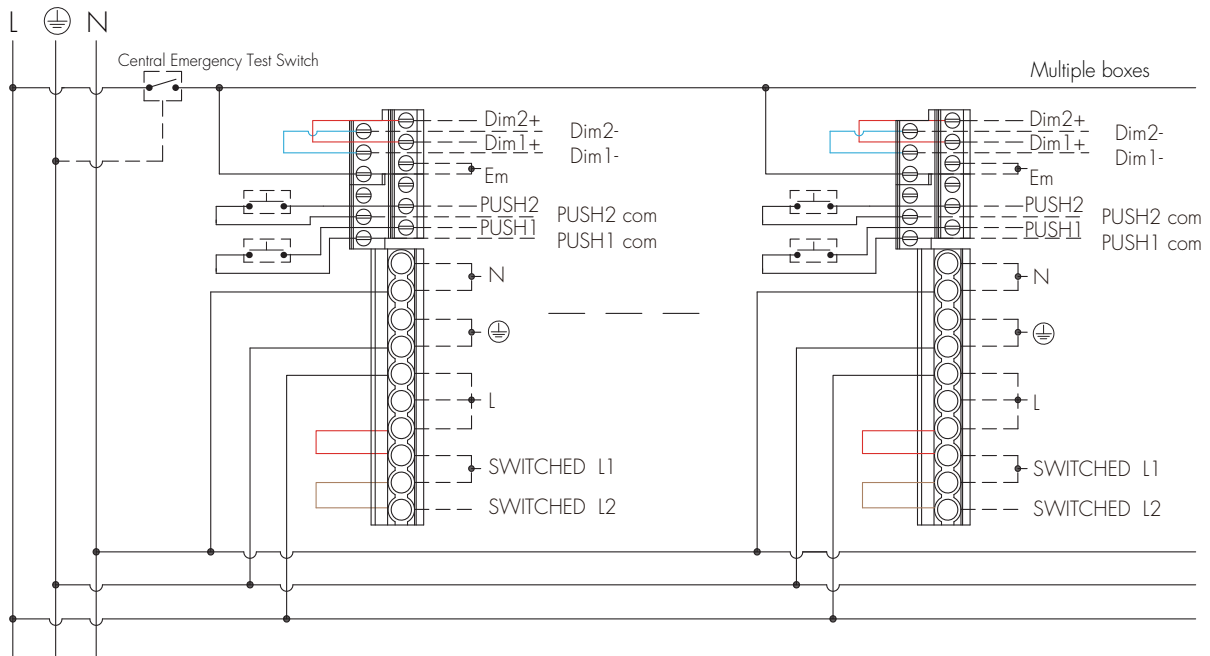

- Note: 1. A local lighting switch may still be used when there is a central emergency test switch.
 2. Do not wire across phases.

9. Ceiling Rose/ Conduit Box Connection

Description

Ceiling rose QCCR02 can be used when there is a need to take power and dimming signal from a conduit box. The installation-friendly design comes with a very spacious termination space for really easy wirings.

Key Features

- Can be freely placed or fixed with BESA/junction box
- Taking power from BESA/junction box
- 6-pole GST type connector (L, E, N, Em, Dim+, Dim-)
- Allowing fast connection with Hytronik quick connection box
- 15mm depth big cabling space
- 48-68mm pitch for conduit mounting
- Nominal current max. 16A
- Flame-retardant material for safety protection

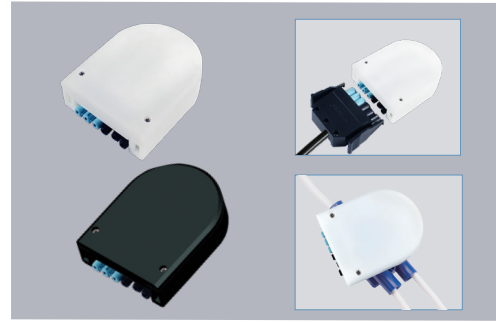

*QCCR02 is supplied with white color housing by default. Black color housing can be supplied upon request.

Mechanical Structure & Dimensions

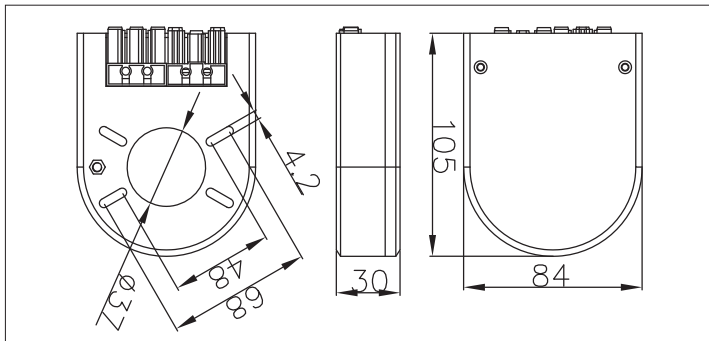

Input & Output Terminal Function

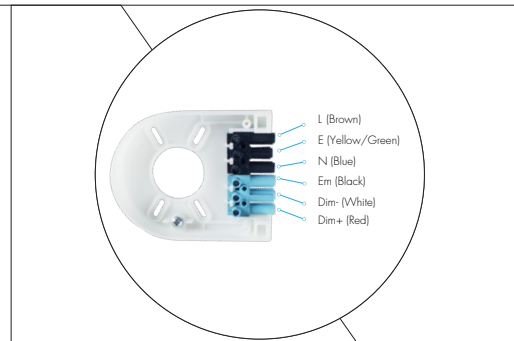

Secure QCCR02 with BESA/Junction box

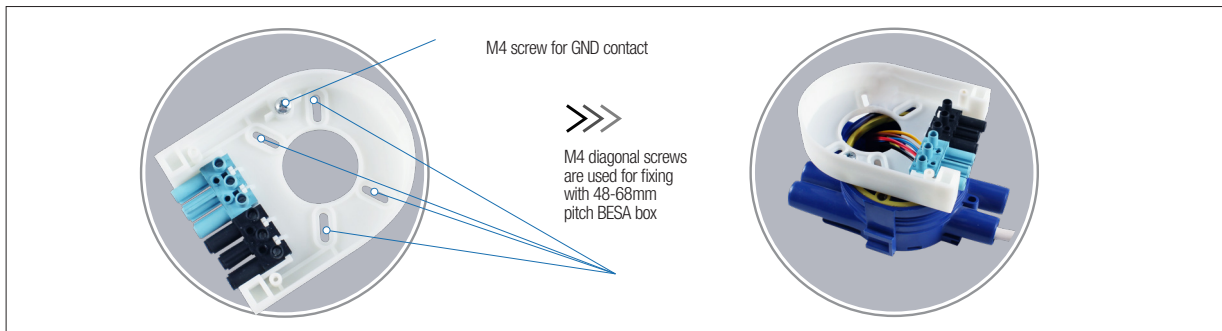

Connection to QCB03/4WAY



Additional Information / Documents

1. Regarding Hytronik standard guarantee policy, please refer to [www.hytronik.com/download ->knowledge ->Hytronik Standard Guarantee Policy](http://www.hytronik.com/download->knowledge->Hytronik%20Standard%20Guarantee%20Policy)