

IP65 PIR Zhaga book 18 Standard Motion Sensor with Bluetooth® 5.0 SIG Mesh

HIR15/BLE

Dimming & Tunable white

HYTRONIK®



Product Description

HIR15/BLE is a Bluetooth dimming and tunable white PIR motion sensor. It is compatible with the Zhaga book 18 standard and designed with a robust IP65 structure, the capability can be up to 12m installation height, which is ideal for the typical outdoor lamp (such as a streetlight). HIR15/BLE is embedded with a Bluetooth module to achieve dimming control and colour tuning. The Bluetooth wireless mesh networking makes communication much easier without any hardwiring, which eventually adds value to luminaires and saves costs for projects. Meanwhile, simple device setup and commissioning can be done via **Koolmesh™** app.



App Features

- Quick setup mode & advanced setup mode
- Tri-level control
- Daylight harvest
- Circadian rhythm (Human centric lighting)
- Floorplan feature to simplify project planning
- Web app/platform for dedicated project management
- Koolmesh Pro iPad version for on-site configuration
- Grouping luminaires via mesh network
- Scenes
- Detailed motion sensor settings
- Dusk/Dawn photocell (Twilight function)
- Push switch configuration
- Schedule to run scenes based on time and date
- Astro timer (sunrise and sunset)
- Staircase function (primary & secondary)
- Internet-of-Things (IoT) featured
- Device firmware update over-the-air (OTA)
- Device social relations check
- Bulk commissioning (copy and paste settings)
- Dynamic daylight harvest auto-adaptation
- Power-on status (memory against power loss)
- Offline commissioning
- Different permission levels via authority management
- Network sharing via QR code or keycode
- Remote control via gateway support HBGW01
- Interoperability with Hytronik Bluetooth product portfolio
- Compatible with EnOcean BLE switches
- Continuous development in progress...

Hardware Features

- Zhaga Book 18 standard
- System DALI power supply
- Tunable white
- IP65 design
- High-bay (up to 12m height)
- 5-year warranty

Bluetooth 5.0 SIG mesh



Smartphone app for both iOS & Android platform



Koolmesh Pro app for iPad

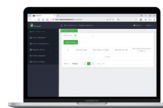

Web app/platform: www.iot.koolmesh.com

Technical Specifications

Bluetooth Transceiver	
Operation frequency	2.4 GHz - 2.483 GHz
Transmission power	4 dBm
Range (Typical indoor)	10~30m
Protocol	Bluetooth® 5.0 SIG Mesh

Input & Output Characteristics	
Operating voltage	12 - 36 VDC
Stand-by power	<0.5W
Output current	Max. 10mA (12VDC)
Lux Range	0~1000 lux

Environment	
Operation temperature	Ta: -20°C ~ +50°C
Storage temperature	-40°C ~ +70°C
Relative humidity	10 ~ 90%
IP rating	IP65
Insulation	Class II

Sensor Data	
Sensor principle	PIR
Detection range*	Max installation height: 12m Max diameter: 20m
Detection angle	360°

* The detection range is heavily influenced by sensor placement (angle) and different walking paces. It may be reduced under certain conditions.

Safety & EMC	
EMC standard (EMC)	EN61547, EN55015
Safety standard (LVD)	EN61347-1 EN61347-2-11
RED	EN300328, EN301489-1/-17EN50663
Certification	CE , UKCA

Mechanical Structure & Dimensions

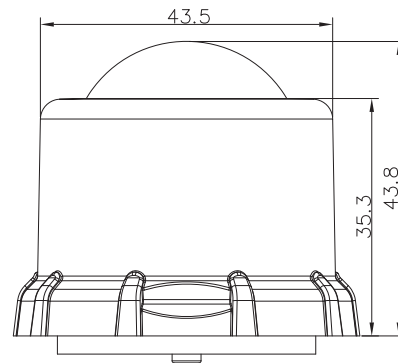
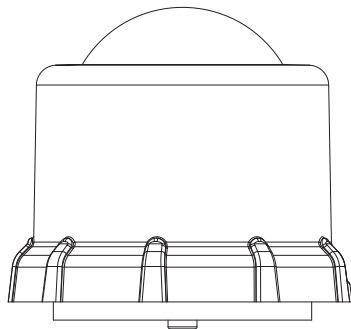
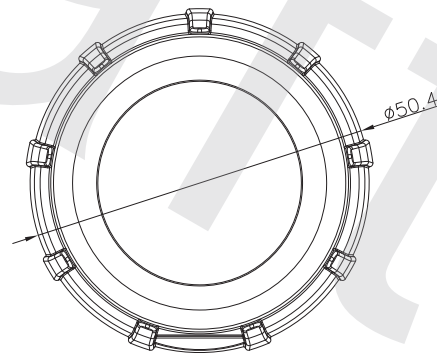
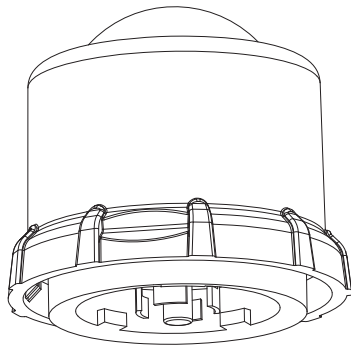

Wiring Diagram 1

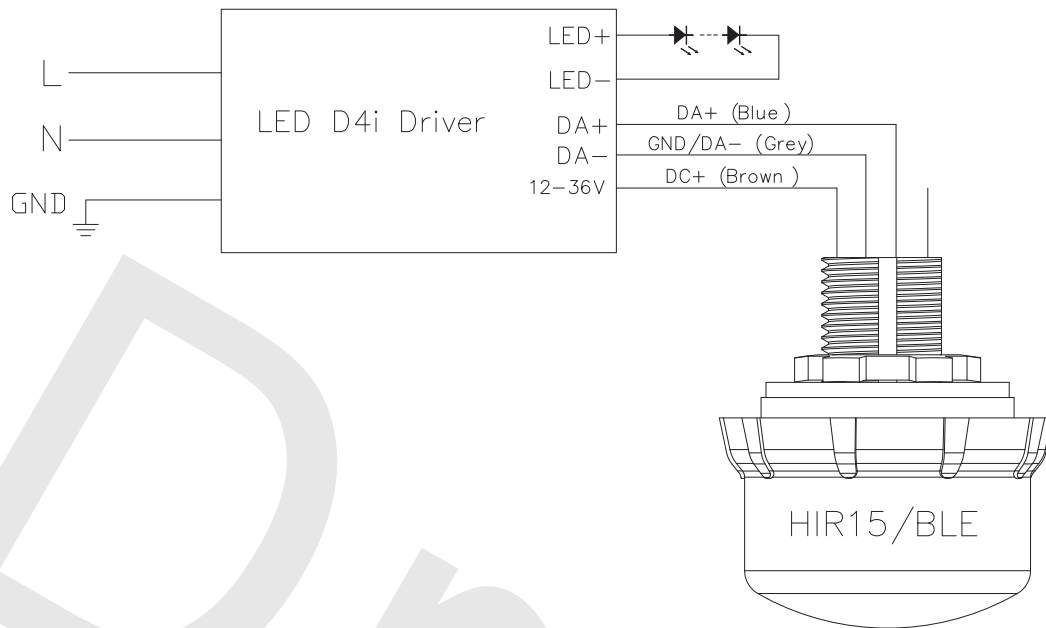

Wiring Diagram 2

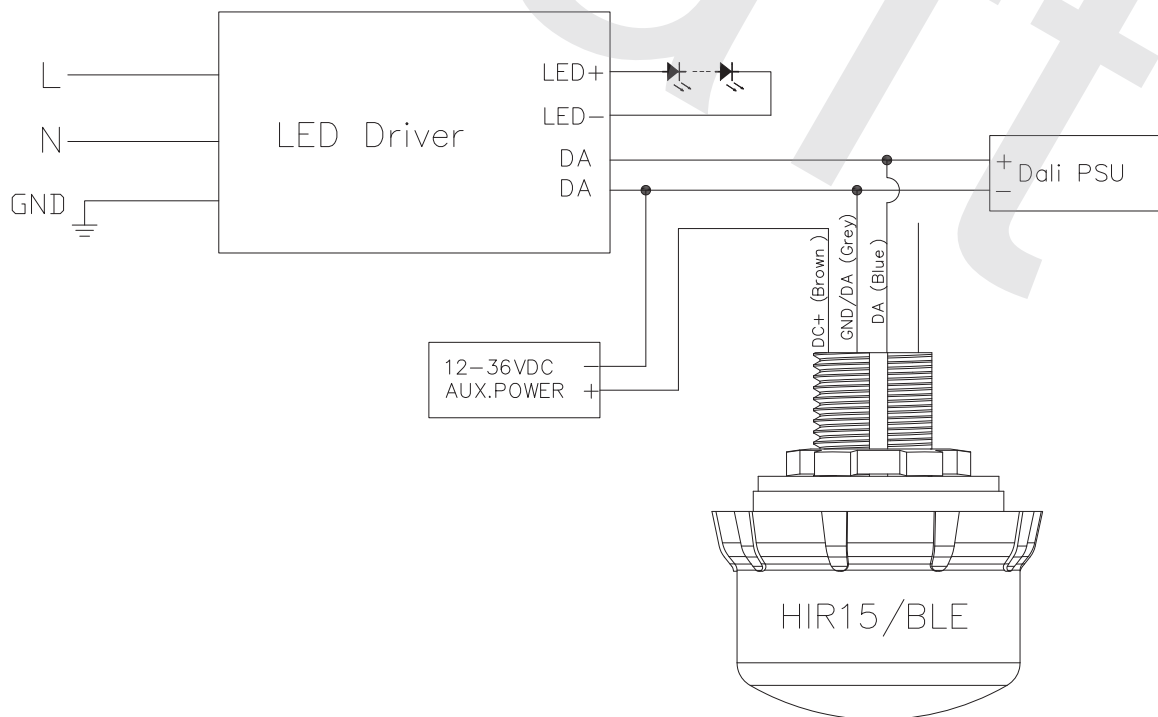

Wiring Diagram 3

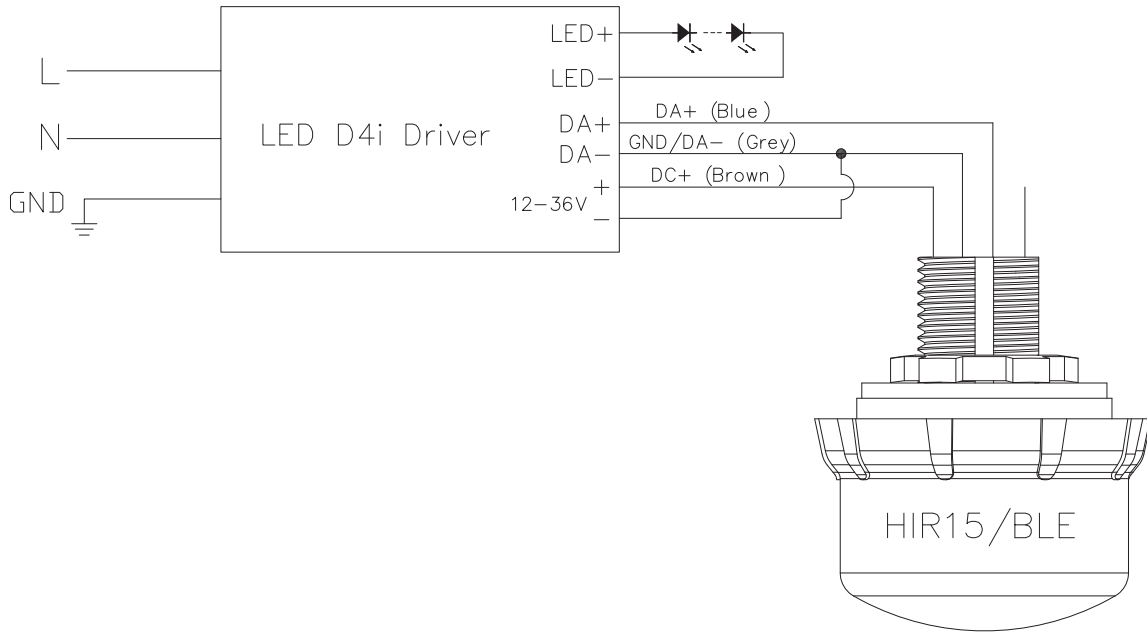

Detection Range

The data below is tested under following conditions:

- Single person walking;
- Sensor not connected to any driver that may have soft-on period;
- Testing temperature $T_a = 30^\circ\text{C}$;
- The testing is conducted in an open and spacious indoor field, without noticeable obstacles or influences that may affect PIR performances.

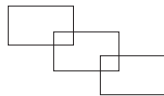

A: Tangential movement	B: Radial movement	Mount height	Tangential Movement (A)	Radial Movement (B)
		3m	max 50m ² (Ø = 8m)	max 13m ² (Ø = 4m)
		5m	max 79m ² (Ø = 10m)	max 13m ² (Ø = 4m)
		8m	max 154m ² (Ø = 14m)	max 13m ² (Ø = 4m)
		12m	max 314m ² (Ø = 20m)	max 13m ² (Ø = 4m)

Smart Phone to Device Range

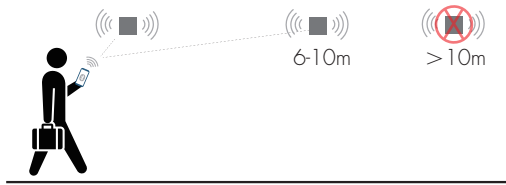

The smart device with the App installed will have a typical range of 10m, but varies from device to device. During commissioning, the installer will need to be in range of the devices when searching for devices to add to the network.

Once the devices have been added to the network via the App, the devices will start communicating within the wireless mesh. This means that once the network is complete, all devices are accessible from the smart device when in a 20m range of a single point.

Additional Information / Documents

1. To learn more about detailed product features/functions, please refer to [www.hytronik.com/download ->knowledge ->Introduction of App Scenes and Product Functions](http://www.hytronik.com/download->knowledge->Introduction%20of%20App%20Scenes%20and%20Product%20Functions)
2. Regarding precautions for Bluetooth product installation and operation, please kindly refer to [www.hytronik.com/download ->knowledge ->Bluetooth Products - Precautions for Product Installation and Operation](http://www.hytronik.com/download->knowledge->Bluetooth%20Products%20-%20Precautions%20for%20Product%20Installation%20and%20Operation)
3. Regarding precautions for PIR Sensors installation and operation, please kindly refer to [www.hytronik.com/download ->knowledge ->PIR Sensors - Precautions for Product Installation and Operation](http://www.hytronik.com/download->knowledge->PIR%20Sensors%20-%20Precautions%20for%20Product%20Installation%20and%20Operation)
4. Data sheet is subject to change without notice. Please always refer to the most recent release on [www.hytronik.com/products/bluetooth technology ->Bluetooth Sensors](http://www.hytronik.com/products/bluetooth%20technology->Bluetooth%20Sensors)
5. Regarding Hytronik standard guarantee policy, please refer to [www.hytronik.com/download->knowledge ->Hytronik Standard Guarantee Policy](http://www.hytronik.com/download->knowledge->Hytronik%20Standard%20Guarantee%20Policy)