



HCD418-I

Fixture Built-in DALI Motion Sensor

Tri-level Control



Introduction

This product utilises photocell advance technology to realise occupancy and true automatic photocell functions in one product. The technology allows luminaire design to be simplified as the luminaire body no longer needs to be drilled to accept a photocell for assessing the daylight condition. This sensor can tell the difference of nature light and artificial light (LED) from behind the diffuser, and measure ambient natural light then calculate how much artificial light is needed to reach the target lux level. The need is passed to the driver by DALI signal for delivering the right amount of light.

The light will be dimmed to minimum level and switched off eventually if ambient daylight is sufficient, no matter it is during hold-time or stand-by time, with or without motion.

Technical Specifications

Product type	Built-in DALI motion sensor (Tri-level control)
Operating voltage	120~277VAC 50/60Hz
Switched power	max. 20 devices max.40mA
Stand-by power	< 1W
Detection settings	50% / 100%
Hold time	5s / 3min / 10min / 30min
Stand-by time	0s / 10s / 1min / 5min / 10min / 30min / 1h / +∞
Stand-by dimming level	10% / 30%
Daylight threshold	2 ~ 50Lux , Disable
Detection area (DxH)	12 x 6 m
Microwave frequency	5.8 GHz +/- 75Mhz
Microwave power	<0.2 mW
Warming-up time	20s
Operating temperature	-20°C ~ +60°C

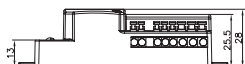
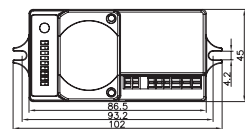
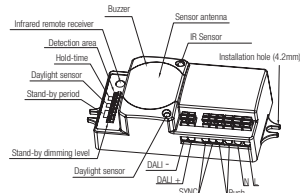

Dimensions (mm)

Diagram 1. Typical layout - in front of LED PCB

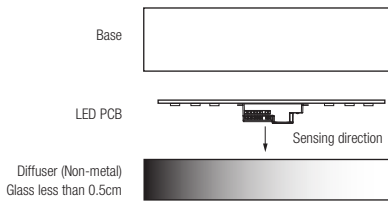
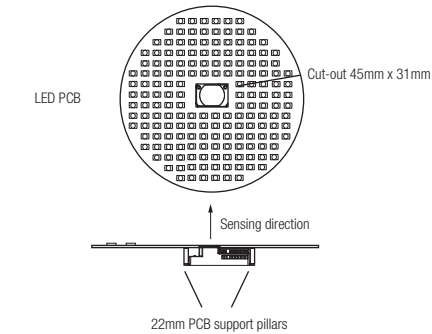

Diagram 2. Typical layout - behind LED PCB with cut-out



Installation

Please read this manual carefully before installing the microwave sensor and siting the luminaire.

Both the microwave sensor (antenna) and the photocell elements of the product must be in front of any metal work and have full line of sight to the cover/diffusing element of the fixture for trouble-free operation.

After Installing the sensor, it is highly recommended that the luminaire is tested for compatibility and correct operation of all components.

Note: If testing under laboratory conditions, the unique nature of this product requires full bandwidth of the visible and invisible parts of the electromagnetic spectrum, therefore it is not recommended to attempt daylight simulation with artificial light sources.

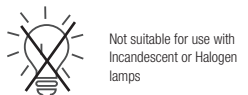

Preparation of Luminaire

1. Positioning

This microwave sensor is ideal for use with LED luminaires with the following considerations:

For simple mounting, the sensor may be placed on the LED side of the LED PCB. The microwave sensor will not be able to "see" through any metal components of the fixture. (See diagram 1 opposite).

For shadow-free operation, it is recommended that the LED PCB is designed with a viewing window for the sensor so that it may fit flush (or slightly proud) of the LED PCB. (Please refer to diagram 2)

2. Configure the luminaire

Referring to the wiring diagrams overleaf, it is best to consider terminations of the luminaires offered to the installer dependant on system or project design. If in any doubt, it is recommended that all 8 terminals of the sensor are made accessible to the installer so that all of the features may be used if required.

3. Wiring

To assist with installation, Hytronik use push-wire style terminals. It is recommended that single core (1/0.8mm for example) is used for making the connections to the sensor.

The full specification for the wiring terminal is:

- Wire preparation
- 16-18AWG □
- 8mm

Functions

Photocell Advance (Lux off Function)

The built-in sensor can measure ambient natural light behind the diffuser, dim and eventually switch off the fixture when artificial light is not required. What's more, if the stand-by time is pre-set at "+∞", the fixture can automatically turn on at dim level when natural light is insufficient.

Tri-level Control (Corridor Function)

Hytronik builds this function inside the motion sensor to achieve tri-level control, for some areas require a light change notice before switch-off.

It offers 3 levels of light: 100%-->dimmed light-->off; and 2 periods of selectable waiting time: motion hold-time and stand-by period; Selectable daylight threshold and freedom of detection area.

Synchronization Control Function

By connecting the "SYNC" terminals in parallel (maximum 10pcs, see wiring diagram next page), no matter which sensor detects motion, all HCD418-I connected will turn on the lights when surrounding natural light is below the daylight threshold which can be set by either DIP switch on the sensor unit or remote control HRC-11. The sensor antennas are effectively 'shared' and the detection area is widely enlarged in this way.

Note: To avoid fixtures turning on unnecessarily, daylight sensing takes priority on a point-by-point basis. Occupancy sensing (SYNC) is disabled on those units in which the ambient light exceeds the daylight threshold.

Manual Override (Push Function)

With the help of push-switch, this sensor maybe over-ridden by the end-users to switch on/off the lights manually, or adjust the light brightness during motion hold-time. This makes the product more user-friendly and offers more options to fit for extra-ordinary demands.

* Short push (<1s): on/off function;

On → off: the light turns off immediately and cannot be lightened for a certain time (equals to hold-time preset) even movement is detected. After this period, the sensor goes to sensor mode.

Off → on: the light turns on 100% and goes to auto sensor mode, even when ambient Lux level exceeds the daylight threshold.

* Long push (>1s): adjust the target lux level by turning the light up or down. Both the adjustment on remote control and push switch can overwrite each other, the last adjustment remains in memory.

Note: if no end-user adjustment is desired, simply leave the "push" terminal disconnected.

Semi-auto Function (absence detection)

The motion sensor is employed, but only activated on the manual press of the push switch. Light remains on during the presence and can interact with ambient natural light, then dims down in absence, eventually switching off automatically after the stand-by time has expired.

Note: end-user can choose either Manual Override Function or Semi-auto Function application. Default function is manual override (push function).

Settings

1. Detection Range

Sensor sensitivity can be adjusted by selecting the combination on the DIP switches to fit precisely for each specific application.

	1	
I	●	100%
II	○	50%

2. Hold Time

Select the DIP switch configuration for the light on-time after presence detection. This function is disabled when natural light is sufficient.

	2	3
I	●	5s
II	○	3min
III	○	10min
IV	○	30min

3. Daylight Threshold

Set the level according to the fixture and environment. The light will not turn on if ambient lux level exceeds the daylight threshold preset. Please note the ambient lux level refers to internal light reaching the sensor.

	4	5
I	●	Disable
II	○	50Lux
III	○	10Lux
IV	○	2Lux

Disabling the daylight sensor will put the sensor into occupancy detection only mode.

4. Stand-by period

This is the time period you would like to keep at the low light output level before it is completely switched off in the long absence of people.

Note: "0s" means on/off control;

"∞" means the stand-by period is infinite and the light is effectively controlled by the daylight sensor, off when natural light is sufficient and automatically on at dimming level when insufficient.

	6	7	8
I	●	●	0s
II	○	○	10s
III	○	○	1min
IV	○	○	5min
V	○	○	10min
VI	○	○	30min
VII	○	○	1H
VIII	○	○	+∞

5. Stand-by Dimming Level

The setting is used to select the desired dimmed light level used in periods of absence for enhanced comfort and safety.

	9
I	● 10%
II	○ 30%

Terminations and wiring diagrams

Basic

Point-by-point basic end user installation

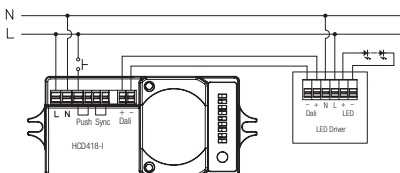

Synchronised - 'Master'

Sync terminal to other sensor luminaires

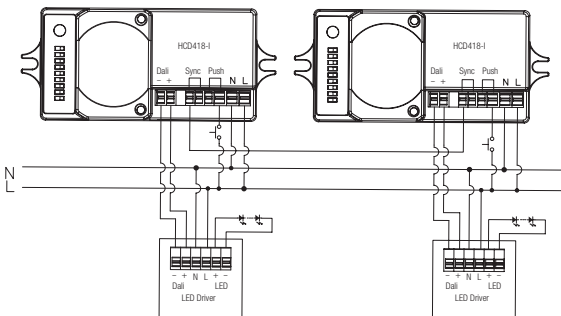

Description of the Button Functions (remote control HRC-11)

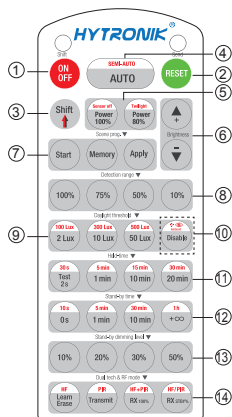

HRC-11

Permanent ON/OFF [button ①]

Press button ① to select permanent ON or permanent OFF mode.
* Press button ②/③ to resume automatic operation.
The mode will change to AUTO Mode after power failure.

RESET [button ②]

Press button ②, all settings go back to the DIP switch settings.

Shift [button ③]

Press button ③, the LED on the top left corner flashes to indicate mode selection.

All values / settings in RED are in valid for 20 seconds.

Auto Mode [button ④]

Press button ④ to initiate automatic mode. The sensor starts working and all settings remain as before the light was switched ON/OFF.

Semi-auto Mode [button ⑤ & ⑥]

1. Press button ⑤ Shift (the red LED is on for indication),
2. press button ⑥ to initiate semi-auto mode. The fixture is manually on by push-switch and will automatically turn off after stand-by period.

Power output [button ④]

Press button ④, the light output shifts between 80% and 100%.
Note: the function of "Sensor off" and "Twilight" are disabled.

Brightness +/- button ③]

Press button ③ to adjust the light output brightness and set as a new target lux level. The built-in daylight sensor can measure ambient daylight level from behind the diffuser and calculates how much artificial light is needed to maintain the target lux level.

Scene prog. [zone ⑦] (One-key-commissioning)

1. Press button "Start" to program.
2. Select the buttons in "Detection range", ⑩ "Daylight threshold", ⑪ "Hold time", ⑫ "Stand-by time", ⑬ "Stand-by dimming level" to set all parameters.
3. Press button "Memory" to save all the settings programmed in the remote control.
4. Press button "Apply" to set the settings to each sensor unit(s).
For example, to pre-set detection range 100%, daylight threshold Disable, hold time 5min, stand-by time +∞, stand-by dimming level 30%, steps should be:
Press button ⑦ Start, button ⑩ 100%, ⑪ Disable, ⑫ Shift, ⑬ 5min, ⑭ Shift, ⑮ +∞, ⑯ 30%, ⑰ Memory. By pointing to the sensor unit(s) and pressing ⑱ Apply, all settings are passed on the sensor(s).

Detection range [zone ⑩]

Press buttons in zone ⑩ to set detection range at 100% / 75% / 50% / 10%.

Daylight threshold [zone ⑪]

Press buttons in zone ⑪ to set the daylight sensor at 2Lux / 10Lux / 50Lux / 100Lux / 300Lux / 500Lux or Disable.

Note: To set daylight sensor at 100Lux / 300 Lux / 500Lux, press button ③ Shift at first.

Ambient daylight threshold [button ⑪]

1. Press button ③ Shift, the red LED flashes for indication.
2. Press button ⑪, the ambient lux level is sampled and set as the new daylight threshold.

Hold time [zone ⑫]

Press buttons in zone ⑫ to set the hold time at 2s / 30s / 1min / 5min / 10min / 15min / 20min / 30min.

Note: 1. To set hold-time at 30s / 5min / 15min / 30min, press button ③ Shift at first.

2. 2s is for test purpose only, stand-by period and daylight sensor settings are disabled in this mode.

*To exit from Test mode, press button ② or any button in zone ①.

Stand-by time [zone ⑬]

Press buttons in zone ⑬ to set the stand-by period at 0s / 10s / 1min / 5min / 10min / 30min / 1h / +∞.

Note: "0s" means on/off control; "+∞" means the stand-by time is infinite and the light is effectively controlled by the daylight sensor, off when natural light is sufficient and automatically on at dimming level when insufficient.

Stand-by dimming level [zone ⑬]

Press buttons in zone ⑬ to set the stand-by dimming level at 10% / 20% / 30% / 50%.

Dual tech & RF mode [zone ⑭]

All buttons in zone ⑭ are disabled.